

 **YAMAHA**

# *Drums*

HANDCRAFTED SINCE 1967

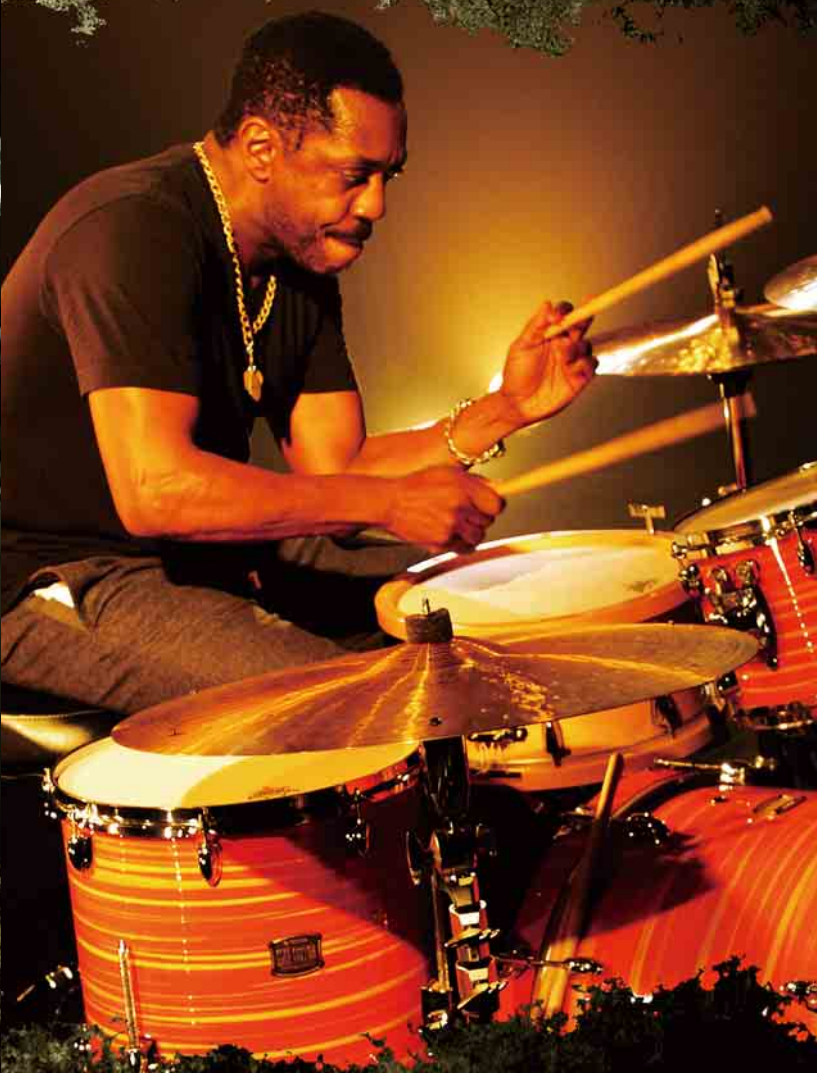

<http://www.yamaha.co.jp/english/product/drums/>

In 2007, we celebrated our 40th anniversary in manufacturing drums with the introduction of the PHX Series drums—a high-end series that brings together the knowledge and skills we've gain over the past 40 years making drums.

Since their introduction these drums have received high acclaim from professional drummers who are serious about their sound. They have also proven that drums, as musical instruments, can be improved upon.

In 2009, we introduced an all-new Absolute Series. Redesigned from the ground up, these drums inherit the concepts and skills acquired in the design of our PHX Series. Even the hardware has been redesigned in order to provide the utmost in operability, stability, and durability.

Select materials, precision processing, acoustically engineered designs and the skills of our master craftsmen. With these resources at our disposal, we turned to drummers for their valuable insight and began building numerous prototypes in our quest to design the best drums possible.

Driven to deliver the best in musical instruments, we continue setting our sights higher in our search for perfection.

## Yamaha—Drum Manufacturing with Tradition

### Bass Drum "R-Version"

When using a rack system or for musicians who don't want to obstruct the tonality of the bass drum by mounting a tom, the "R-Version" Bass Drum has been introduced to the PHX Series and Absolute Series. Now you can experience every bit of that pure bass drum sound.

(for PHX Series, Absolute Series, Oak Custom, RockTour)

### Bass Drum Spurs

The result of years of refinement, Yamaha bass drum legs prevent bass drums from creeping forward, in most instances without carpets or tacky underlays. Quick and easy to use, Yamaha bass drum legs keep bass drums rigid and immovable, even under the hardest pounding. Thicker tubing, combined with drum key operated height adjustability and easy-slide metal points, as found on our cymbal stands, provide enhanced stability.



# INDEX

INTRO INDEX \_\_\_\_\_ 1

## SYSTEM DRUMS

PHX Series _____	5
Absolute Series _____	7
Recording Custom _____	13
Club Custom _____	15
Oak Custom _____	17
Rock Tour _____	19
Tour Custom _____	21
Stage Custom _____	23
GIGMAKER _____	25
SPECIFICATION _____	27

## SIGNATURE SERIES

Hippig _____	31
Hippig Sr. _____	32
Club Jordan Cocktail Drum System _____	32
Junior Kit _____	33
Subkick _____	34
Wedges _____	34

## SNARE DRUMS

Philosophy of the Yamaha Snare Drums _____	35
New Concept Snare _____	41
Wood Snare Series _____	43
Metal Snare Series _____	45

## Artist

Yamaha Drummers _____	47
Signature Snare Series _____	53

## HARDWARE

Foot Pedal _____	57
Hi-hat Stand _____	63
Snare Stand _____	67
Cymbal Stand _____	67
Tom Holder _____	71
Double Tom Stand _____	73
Drum Stool _____	73
Accessories _____	75

DTX DRUMS _____	77
-----------------	----

## Ball Mount & Clamp

A tribute to Yamaha design technology, our original ball mount and clamp has gone through very few modifications over the years. A large, ultra-hard resin ball sits in an attractive chromed housing, held in place with a titanium ergonomic wing bolt. It is the ultimate drummer-friendly mount, offering non-slip positioning virtually anywhere the drummer can imagine. Additionally, it permits tuning of the bottom head by simply rotating the drum.

## Vent Holes

The number of vent holes influences both the drum's timbre and projection. PHX Series and New Absolute Series are designed with one to ten vent holes, depending upon the drum's dimensions. By varying the number of holes, particularly on larger shells, the drum's sustain length, amount of mid-bass tone, and playing comfort can all be fine-tuned.

## Floating Bass Drum System

A pipe post stabilizer on the pedal side of the bass drum provides height adjustment and positions the beater so that it strikes the center of the bass drum batter head. A memory clamp on the pipe slides into a special receiver on the bottom of the bass drum, allowing for quick set up and exact height retention. (for Absolute Series, Oak Custom)



\*Some models may not be available in some countries.

\*Colors shown in this catalog may not be represented exactly as the original colors due to printing processes involved.

\*Specifications are subject to change without notice.

## “Air Seal System” Technology

At Yamaha, the process of manufacturing drum shells begins with the selection of the materials. Select woods are cut into sheets with precision cut diagonal ends. The plies are fit into a form and hammered into place by a highly skilled craftsman. The angled ends allow the craftsman to finely adjust the ply length, thus maintaining proper tension. Ply joints are staggered by 120-degrees and hammered into place in the same manner. An air bag placed inside of the shell and inflated at high-pressure puts even pressure on the shell’s inner surface creating a perfectly round shell with uniform thickness and excellent durability.

This is the Air Seal System, a process that has been in use at Yamaha for over 40 years.



## Shell Materials



### MAPLE

Hard, dense maple delivers a warm tone with outstanding sustain and is considered an excellent material for making drums.

Yamaha goes to great lengths, sorting the woods into finer grades and using them accordingly. Maple produces a versatile tone that blends well with a wide range of musical styles, making it popular with drummers from all over the world.

### BIRCH

Yamaha’s use of birch is longstanding. Remarkably easy to work with, this hard, finely grained wood offers excellent mid and low sustain with a solid, well-defined high range. Our original “Recording Custom” drums are made from birch grown in Hokkaido Japan.

### OAK

Yamaha has developed special techniques for employing oak, previously considered unworkable for drums. Our oak shells offer tone that is at once loud, sensitive, ringing, clean, and vibrant. While its inherent power makes it the ideal heavy metal drum shell, its stark clarity at low volumes have made it a new discovery for jazz players. Oak is as individual as the drummer playing it.

## Hybrid Shell Construction for PHX Series (Patent Pending)

With the wealth of knowledge that YAMAHA has amassed through the decades as the preeminent maker of musical instruments, YAMAHA’s wood specialists have discovered new materials that provide optimal drum performance.

Jatoba, a Brazilian wood and the hardest material in the PHX hybrid shell, is positioned as the core ply and center note of the drum. It is surrounded on either side by layers of kapur, a Malaysian hard wood. North American Maple, which had long been considered a classic, high-quality drum shell material because of its hardness and viscosity, is actually the softest wood in the shell construction; maple is the outer and inner plies of the shell.

This is the process used to complete the hybrid shell, in which the stiffness of the shell shifts from the center toward the outside: the woods are hardest at the center and get softer toward the outer surfaces in either direction. This results in an “excitation structure” that maximizes the shell’s performance. The excitation structure increases the head’s vibration to its full extent, achieving a sound unlike anything you’ve heard before. It produces an effect in sound waves similar to rippling waves caused by a pebble dropped in water.

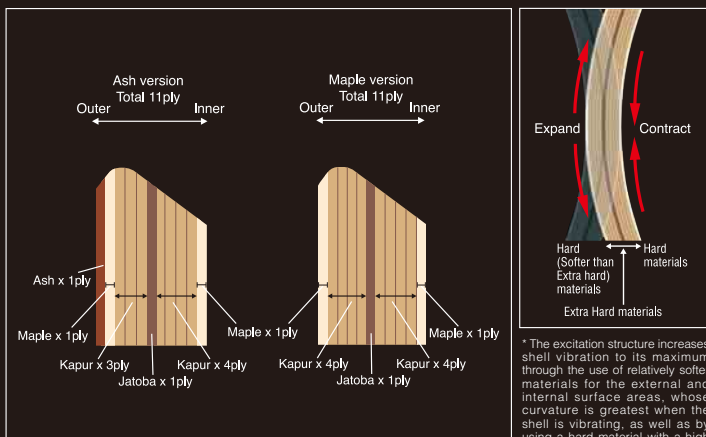

\* The excitation structure increases shell vibration to its maximum through the use of relatively softer materials for the external and internal surface areas, whose curvature is greatest when the shell is vibrating, as well as by using a hard material with a high “spring” property for the core of the shell lamination.



# High Performance Lugs

Yamaha lug casings hold tension rods firmly in place. They afford precise tuning in the smallest increments and do not slip. From our truly innovate Hook Lugs which offer lightning quick changes, to fixed small lugs. (Absolute and Oak Custom lugs) Each is low mass and is designed to promote optimum shell resonance.

Our legendary one-piece high-tension lugs are precision-machined to allow severe, high tension tuning also reinforced the shell.

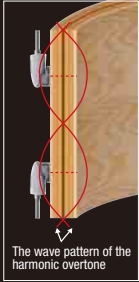

Hook Lug



Absolute Lug



High Tension Lug

# Yamaha Enhanced Sustain System—YESS / YESS II / YESS II-m

The secret of our YESS system is twofold: First, it provides minimum contact of hardware with shell; second, it connects that hardware at the nodal point\* of the drum—the point at which it will not interfere with shell vibration. Nylon bushings on rod clamps afford maximum stability. The YESS system permits toms to be placed close together, and does not interfere with quick head changes. On floor toms, our YESS system offers wide open sustain while keeping toms stable under the heaviest strokes.

The newly evolved YESS II Shell Mounting System makes the most of the shell's vibration. Employing a special new rubber material and the "wood plate mounting" method, vibrations from the shell and hardware can be separated, thus minimizing unwanted resonance. Also, by positioning a part of that special rubber material at the belly area (where overtones are present) while most of them are positioned at the nodal point, the appropriate amounts of sustain and overtone control are simultaneously produced.

And also newly evolved YESS II-m is using same technology but using metal plate instead of wood plate.



A detailed drawing of Special Rubber

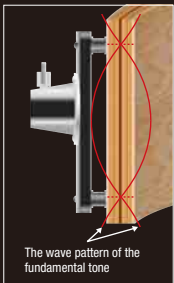
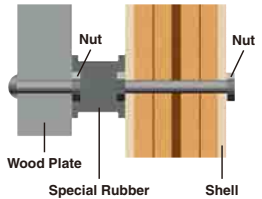

YESS II



YESS II-m



YESS



# PHX Series

## The PHX Series, from the YAMAHA Drum Laboratory

At YAMAHA, prototype drums are the starting point of each drum's evolution. These prototypes are created in the Drum Laboratory where YAMAHA continually pursues the essence of musical perfection.

Under a completely new concept, the PHX (pronounced "phoenix") Series is the pinnacle of excellence in this prototyping process. Handcrafted by our expert technicians, it's based on over 40 years of history, tradition, experience, and technology.

The newly developed PHX Series reveals YAMAHA's all-out pursuit of the ultimate in drum craftsmanship and sound.



**Shells**  
PHXB2418MR x 2  
PHXF1615M  
PHXF1413M  
PHXT1310M  
PHXT1007M  
NSD1455

Polar White



**Shells**  
PHXB2216AGR  
PHXT1613AG  
PHXT1411AG  
PHXT1209AG  
PHXT1008AG  
PHXT0807AG  
VSD1460

Textured Amber Sunburst

### A Range of Options

In addition to the qualities of tonality and functionality, YAMAHA has paid special attention to the values of interior and exterior beauty.

The exterior of the PHX shell is available in classic maple or exotic burl ash finishes. Further, the Hook Lugs and aluminum die-cast hoops are available in either gold or chrome options.

Experience the ultimate combination of unparalleled beauty with brilliant color finishes, including the fresh and unique textured paint.



PHX badge with Phoenix



With Gold Parts



With Chrome Parts

## Bearing Edge Shape

To control the drum's tone and articulation, PHX floor tom, tom-tom and bass drum shells each use different types of bearing edges. All bearing edge angles are set at 30-degrees. However, the radiuses of the bearing edges differ to gain optimum acoustic performance from the shell.

Additionally, a secret treatment process is used to ensure that each edge is finished to a perfect smoothness. This guarantees a very easy and wide tuning range.

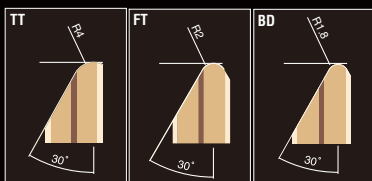

## Color Finishes

### ASH

#### Gloss Finish

#### Textured Finish

Sapphire Fade (SPF)

Turquoise Fade (TQF)

Textured Black Sunburst (TBS)



Garnet Fade (GNF)

Textured Amber Sunburst (TAS)



### MAPLE

#### Gloss Finish

#### Matte Finish

Black Cherry Sunburst (BCS)

Matte Black (MBL)



Polar White (PWH)

Matte Natural (MNT)



### 3 types of surface finish



Gloss Finish



Textured Finish

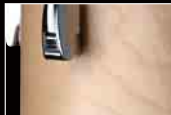

Matte Finish

## Specifications

Diameter x Depth	BD								BD (R Version -without Pipe Clamp)							
	24"		22"		20"		18"		24"		22"		20"			
Model No.	PHXB 2418	PHXB 2416	PHXB 2218	PHXB 2216	PHXB 2018	PHXB 2016	PHXB 1814	PHXB 1814	PHXB 2418R	PHXB 2416R	PHXB 2218R	PHXB 2216R	PHXB 2018R	PHXB 2016R		
Shell	Hybrid Shell															
Lug	Hook Lug															
Hoop	Wood hoop															
No. of Tuning Bolts	10	10	10	10	10	10	8	10	10	10	10	10	10	10		
Head	Batter: Remo PS3 Clear								Front: PS3 SW without Hole [Coated A]		Batter: Remo PS3 Clear					

Diameter x Depth	FT				TT											
	18"	16"	14"	16"	14"		13"		12"		10"		8"			
Model No.	PHXF 1816	PHXF 1615	PHXF 1413	PHXT 1614	PHXT 1613	PHXT 1412	PHXT 1411	PHXT 1310	PHXT 1309	PHXT 1209	PHXT 1208	PHXT 1008	PHXT 1007	PHXT 0808	PHXT 0807	
Shell	Hybrid Shell															
Lug	Hook Lug															
Hoop	Aluminum Diecast Hoop															
No. of Tuning Bolts	8	8	8	8	8	8	8	6	6	6	6	6	6	5	5	
Head	Clear Ambassador(Top) / Clear Ambassador(Bottom)															

# Absolute Series

Yamaha Hand Crafted Drums

## High Quality x Customization

Let's begin with a question: What would your ideal drum kit be like? We could put that question to a hundred drummers, and we'd certainly get a hundred different answers. They'd all talk about the tone, buildup, clarity and stick rebound, but each drummer has his or her own tastes and preferences. Even the shell color would be important.

With YAMAHA's Absolute Series you can create the ideal drum kit by choosing your favorite elements from our highest-quality materials and components.

So, why play just anybody's drum kit when you could have your very own "dream kit"?



Burgundy Sparkle

## Maple / Birch Custom Absolute

### Shells

MAB2220R BAF1615 BAF1413 BAT1208

### Hardware

FP9500Cx2 HS1200D CH750 CH755x4 CSBW SS950 DS840 CL945B

\*The set doesn't include Cymbals, Hardware (except Tom Holder), nor Rack.

\*HEXRACK is limited stock.



Caramel Sparkle

## Maple Custom Absolute

### Shells

MAB1814 MAF1413 MAT1208

### Hardware

FP8500B HS740A CS650A CS655Ax2 SS740A DS840 TH904A CL945B

\*The set doesn't include Cymbals, Hardware (except Tom Holder), nor Rack.





## Birch Custom Absolute

White Grape Sparkle

### Shells

BAB2218HR BAT1412H BAT1411H BAT1209H BAT1008H BAT0807H

### Hardware

DFP9500D HS1200T CH750x2 CH755x4 CSBW CHH930 SS950 DS840

\*The set doesn't include Cymbals, Hardware (except Tom Holder), nor Rack.

\*HEXRACK is limited stock.

## Absolute Lug



Our complete specifications are passed on to succeeding model lines, generation after generation.

The already well-known "Absolute Lug," for instance, can be firmly secured with a single bolt. It's a complete secure lug that doesn't interfere with vibrations of the shell. The insertion plate, which is located within the lug case, and the nylon ring at the lower part of the lug nut control the slackening of the tuning bolt, providing the utmost in tuning stability.

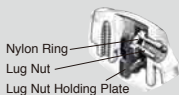

## Hook Lug



The Hook Lug has been redesigned by thoroughly improving our innovative hook-type Nouveau Lug (used in the conventional Absolute Series) in every aspect. At the same time, the greatness of the lug's basic concept has been maintained.

It can be said that the Hook Lug is truly a next-generation lug that transcends conventional lugs with its acoustical effect and tuning stability, as well as with the sturdiness needed for high-tension tuning and the way it facilitates quick head replacement. As with the Absolute Lug, the insertion plate and nylon ring within the lug nut control the slackening of the tuning bolt.



Air-Seal System



Maple Birch



7mm



6mm



Hook Lug



Absolute Lug (Chrome)



Lug Nut



YESS II-m (TT)



YESS (FT)



R-Version BD



3.0 Aluminium Die-cast (3.0mm)



Wood Hoop BD



18" Floating BD System



Bass Drum Spurs



Remo Ebony Power Stroke P3



PS3 Clear Coated Ambassador



Clear Emperor



Clear Ambassador



All Round Ball Clamp (Short Rod)



Triple Tom Holder

Hardware

## Wood

### MAPLE

Carefully selected maple material is used. It offers rich, warm tone and abundant sustain. This material is loved by drummers the world over, and is heard in every musical genre imaginable.

### BIRCH

We use the finest Hokkaido-grown birch material, and it's noted for a fine grain and attractive gloss. Although birch is hard, it has excellent workability. Drummers love its outstanding ability to carry the middle to low tones, as well as its sharp but solid response in the upper register. Birch material is also used for the Recording Custom, which can be considered the foundation of YAMAHA's system drum.

Both the maple and birch shells are available in the seven-ply (BD) and six-ply (FT, TT, SD) specifications. Excellent durability is achieved with the use of premium materials, and through the combination of the air sealing system and YAMAHA's advanced woodworking technologies. The Absolute Series produces a well-balanced rumble. You can choose from a variety of sizes from an 8-inch tom-tom to a 24-inch bass drum.



7ply (BD)



6ply (TT/FT/SD)

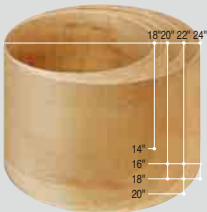

BD



TT

## Vent Hole

The vent hole plays an important role in performance, since it affects not only the sensation of hitting the drum (the impact) but also the initial sound, sustain and tone.

Through an exhaustive series of prototypes, YAMAHA has discovered the optimal number and vent hole position depending on the air capacity of each shell. Particularly, vent holes contribute to the enhancement of tone colors in midrange to low-frequency sounds, as well as the control of sustain.



BD24"-20"



BD18"



FT



TT14"-16"



TT13"



BD8"-12"



SD

## YESS II-m

Y.E.S.S. II is an improved version of YAMAHA's original tom mount, known as the Y.E.S.S. (Yamaha Enhanced Sustain System). Its unique design, which minimizes interference with the shell's natural response—which some call the “rumble”—has been adopted for the PHX Series and is highly praised by pro players worldwide. The Y.E.S.S. II-m model, which uses a metal plate instead of the wood plate found in the Y.E.S.S., has been adopted for the Absolute Series, producing even longer sustain.

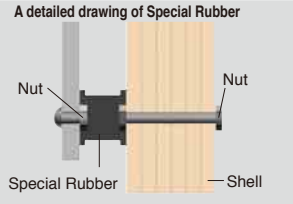
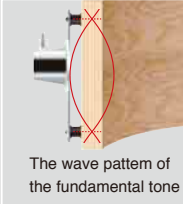

## Set Configuration

Series	Set No.	Bass Drum	Floor Tom	Mounted Tom	Hardware
Maple Custom Absolute Absolute Lug Models	MA2F2	MAB2218	MAF1615	—	TH945B
	MA2RF2	MAB2220R	MAF1615	—	—
	MA2RT2	MAB2218R	—	MAT1412	—
	MA0F2	MAB2016	MAF1413	—	TH945B
	MAT2	—	—	MAT1209, MAT1008	—
Maple Custom Absolute Hook Lug Models (Option)	MAH2F2	MAB2218H	MAF1615H	—	TH945B
	MAHT2	—	—	MAT1209H, MAT1008H	—
Birch Custom Absolute Absolute Lug Models	BA2F2	BAB2218	BAF1615	—	TH945B
	BA2RF2	BAB2220R	BAF1615	—	—
	BA2RT2	BAB2218R	—	BAT1412	—
	BA0F2	BAB2016	BAF1413	—	TH945B
	BAT2	—	—	BAT1209, BAT1008	—
Birch Custom Absolute Hook Lug Models (Option)	BAH2F2	BAB2218H	BAF1615H	—	TH945B
	BAHT2	—	—	BAT1209H, BAT1008H	—

## Specifications

Lug	Absolute Lug or New Hook Lug						
Hoop	Aluminum Die-cast						
BD Head	Front:Ebony PS3 with YAMAHA Logo, Batter:PS3 Clear (only 18"BD Coated Ambassador)						
TT/FT Head	Top:Clear Emperor, Bottom:Clear Ambassador						
SD Head	Top:Coated Ambassador, Bottom:Snare Ambassador						
Tom Mount	New YESS II-m mount						
Sound Holes	BD20"-24"	BD18"	FT	TT14"-16"	TT13"	TT8"-12"	SD"
	10	8	6	4	2	1	1
Bearing Edge	45R1						
BD Tension Bolt	T-Bolt						

Maple Custom Absolute														
BD														
Diameter	24"				22"				20"				18"	
x Depth	x18"		x16"		x20"		x18"		x16"		x18"		x14"	
Model No.	MAB 2418/H	MAB 2418R/HR	MAB 2416/H	MAB 2220/H	MAB 2220R/HR	MAB 2218/H	MAB 2218R/HR	MAB 2216/H	MAB 2018/H	MAB 2018R/HR	MAB 2016/H	MAB 1814/H	MAB 1814F/HF	
No. of Tuning Bolts	10	10	10	10	10	10	10	10	10	10	10	8	8	
TT														
Diameter	18"		16"		14"		13"		12"		10"		8"	
x Depth	x16"	x15"	x13"	x14"	x13"	x12"	x11"	x10"	x9"	x9"	x8"	x8"	x7"	x7"
Model No.	MAF 1816/H	MAF 1615/H	MAF 1413/H	MAT 1614/H	MAT 1613/H	MAT 1412/H	MAT 1411/H	MAT 1310/H	MAT 1309/H	MAT 1209/H	MAT 1208/H	MAT 1008/H	MAT 1007/H	MAT 0807/H
No. of Tuning Bolts	8	8	8	8	8	8	8	6	6	6	6	6	6	5
Birch Custom Absolute														
BD														
Diameter	24"				22"				20"				18"	
x Depth	x18"		x16"		x20"		x18"		x16"		x18"		x14"	
Model No.	BAB 2418/H	BAB 2418R/HR	BAB 2416/H	BAB 2220/H	BAB 2220R/HR	BAB 2218/H	BAB 2218R/HR	BAB 2216/H	BAB 2018/H	BAB 2018R/HR	BAB 2016/H	BAB 1814/H	BAB 1814F/HF	
No. of Tuning Bolts	10	10	10	10	10	10	10	10	10	10	10	8	8	
TT														
Diameter	18"		16"		14"		13"		12"		10"		8"	
x Depth	x16"	x15"	x13"	x14"	x13"	x12"	x11"	x10"	x9"	x9"	x8"	x8"	x7"	x7"
Model No.	BAF 1816/H	BAF 1615/H	BAF 1413/H	BAT 1614/H	BAT 1613/H	BAT 1412/H	BAT 1411/H	BAT 1310/H	BAT 1309/H	BAT 1209/H	BAT 1208/H	BAT 1008/H	BAT 1007/H	BAT 0807/H
No. of Tuning Bolts	8	8	8	8	8	8	8	6	6	6	6	6	6	5

## Color Finishes

		
<b>Burgundy Sparkle (BGS) #57</b>	<b>Caramel Sparkle (CSK) #58</b>	<b>White Grape Sparkle (WGS) #59</b>
		
<b>Luminous White Sparkle (LWS) #63</b>	<b>Solid Silver (SOS) #64</b>	<b>Matte Natural (MNT) #65</b>
		
<b>Solid Black (SOB) #06</b>	<b>Silver Sparkle (SLS) #07</b>	<b>Black Sparkle (BLP) #08</b>
		
<b>Black Sparkle Sunburst (BSS) #29</b>	<b>Blue Sparkle (BUP) #46</b>	<b>Red Sparkle (RDS) #47</b>

### What is "Vintage Finish"

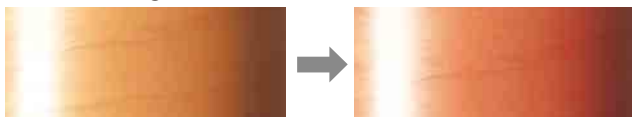

The Vintage Finish is a special process developed by YAMAHA using a top-quality drum coating material. The use of this unique coating allows us to create a finish that's far thinner but harder than the regular coating material. As a result, it's possible to ensure the maximum vibratory response from the shell and achieve a more brilliant, beautiful appearance. The Vintage Finish coating also protects the shell laminate from humidity. One of its special features is that the color can become even more intense after the coating is applied, depending on the wooden material's surface condition, physical properties of the coating material and other conditions such as ambient temperature and light. Please note that although individual differences in color may occasionally appear depending on the condition of the wooden laminate (which consists of natural materials), the period of purchase and the product's storage condition, it's one of the special features of this coating specification. Therefore, it won't affect the tonality of the product.





Blue Ice Sparkle (BIS) #60



Midnight Skyblue (MNB) #61



Deep Blue (DBU) #62



Vintage Natural (VN) #01



Vintage Black (VB) #02



Cherry Wood (CW) #04



Red Pearl Natural (RPN) #09



White Marine Pearl (WMP) #11



Apple Sparkle Fade (ASF) #28



Cherry Black Fade (CBF) #51



Midnight Sparkle (MNS) #52



Embossed Silver (ESL) #56

## Midnight Sparkle



The Midnight Sparkle finish has a black sparkle finish base. Please understand that the colors in this finish change in relation to light conditions and the angle at which you look at the drum, so the actual appearance might differ from that shown in the photo.

## Luminous White Sparkle



This newly developed Luminous White Sparkle appears to be a regular white sparkle under normal lighting. But be forewarned: Thanks to a special fluorescent coating, this spectacular finish glows in the dark. Even on a dark stage, your YAMAHA Absolute kit will establish its own unique territory!

# Recording Custom

For over 30 years, the Recording Custom has set a benchmark for excellence. Possibly the most recorded drum in history, it has enjoyed an unparalleled history of success and innovation. Although trends come and go, the Recording Custom, with its birch shells and pristine interior and exterior finish, delivers a sound that seems “pre-EQ-ed”, perfect for studio or multi-miking in any situation. Unmiked, it will hold its own—with power and tone to spare.



## Recording Custom

### Shells

BD924Yx2 FT918Y FT916Y TT914Y TT912Y

\*Cymbals and Hardware (except Tom holder/Tom clamp) are not included.

### All Birch Shells

Recording Custom shells are crafted from select cuts of birch. Floor toms and tom toms are formed with 6-ply designs while bass drums use 7-plyes. The series is available in two color finishes, a traditional cherry wood finish and solid black.

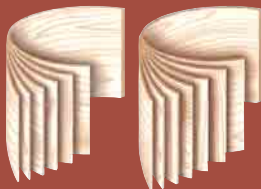

### Hi-Tension Lugs

Yamaha's one-piece high-tension lugs are precision-machined to allow severe, high tension tuning.

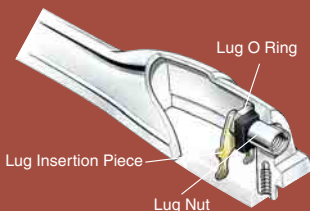



## Color Finishes



CW : Cherry Wood



SOB : Solid Black

## Set Configuration

Set No.	Individual Package Contents	Bass Drum	Floor Tom	—	—
		Mounted Tom	Mounted Tom	Tom Holder	Tom Clamp
RY2F4	RY2F41	BD922Y	FT916Y	—	—
	RY2F42	TT912Y	TT913Y	TH945B	—
RY2T4	RY2T41	BD922Y	TT914Y	—	—
	RY2T42	TT910Y	TT912Y	TH945B	CL945B
RY0T4	RY0T41	BD920Y	TT914Y	—	—
	RY0T42	TT910Y	TT912Y	TH945B	CL945B

## Specifications

		BD					FT			TT						
Diameter		26"	24"	22"	20"	18"	18"	16"	14"	16"	15"	14"	13"	12"	10"	8"
Standard Size	x Depth	x14"	x14"	x14"	x14"	x14"	—	—	—	—	x12"	x10"	x9"	x8"	x7 1/2"	—
	Model No.	*BD 926YJ	*BD 924YJ	BD 922YJ	BD 920YJ	BD 918YJ	—	—	—	—	TT 915YJ	TT 914YJ	TT 913YJ	TT 912YJ	TT 910YJ	—
Power Size	x Depth	—	x16"	x16"	x16"	—	x16"	x16"	x14"	x14"	x13"	x12"	x11"	x10"	x9"	x8"
	Model No.	—	*BD 924Y	BD 922Y	BD 920Y	—	FT 918Y	FT 916Y	FT 914Y	TT 916Y	TT 915Y	TT 914Y	TT 913Y	TT 912Y	TT 910Y	TT 908Y
No. of Tuning Bolts		10	10	10	10	8	8	8	8	8	8	8	6	6	6	5

\*denotes made-to-order. (Unit: inch)



Air-Seal System



Birch



BD 7-ply



FT/TT 6-ply



Standard Size (BD, TT)



Power Size (BD, TT)



High Tension Lug (One-piece)



Lug Nut



Triple flange (Steel / 1.6mm)



YESS (TT)



YESS (FT)



Pipe Clamp



Bass Drum Spurs



Yamaha Stage Head (Front 20"-26")



Yamaha Stage Head (Front 18")



BD (Batter)



FT/TT (Top)



FT/TT (Bottom)



Hardware



Remo Pinstripe



Remo Clear Ambassador



All Round Ball Clamp (Short Rod)



Triple Tom Holder

# CLUB CUSTOM

## New Wood, New Sound, New Series

Our flagship PHX series drums radically changed drum design using a special blend of newfound Asian woods to deliver an amazing tone that has gained great acclaim from drummers around the globe. The major component in the mix and the wood that gives these ultra high-end drums their characteristic warmth, is a wood called Kapur. The sound of Kapur is now available in a brand new series of drums—the new Club Custom. Made from 100% Kapur the Club Custom drums provide musicians with a new tonality for creating great music. Warm and dry they play well with a wide variety of musical styles. Sound balance is great making them perfect for use in the recording studio, and they have a soft, mild character that lays down exceptionally well behind vocals. Besides sounding great, Club Custom drums look great too with three special “Swirl” finishes and two “Matte Wood” finishes to choose from. Club Custom drums offer a fresh, unique sound that opens up a whole new range of tonal possibilities for the drummer.



### Black Wood set

Shell: CCB2215 CCF1615 CCT1208 CCS1455  
Hardware: FP8500B HS1200 CS755 x 3 SS950 DS840



### Bass Drum Claw Hooks

Claw hooks on the bass drum deliver a classic look that defines the attitude of the Club Custom.

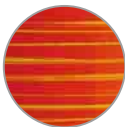

### The Swirl Finish

Resembling a vintage wrap covering, the finish is painted directly onto the shell so as not to affect the shell's superb resonance.

## Specifications

	Bass Drum			Floor Tom			Tom Tom					
Size (Diameter x Depth)	18"x15"	20"x15"	22"x15"	24"x15"	14"x13"	16"x15"	18"x16"	8"x7"	10"x7"	12"x8"	13"x9"	
	CCB1815	CCB2015	CCB2215		CCF1413	CCF1615	CCF1816	CCT0807	CCT1007	CCT1208	CCT1309	
R version without pipe clamp		CCB2015R	CCB2215R	CCB2415R								
Shell	Kapur 6ply											
Lug	Separate lug (Oak type)											
Hoop	Wood Hoop						1.6mm steel triple flange hoop					
Head	Front: P3 Smooth White Batter: Remo Clear P3 (20"-24") Remo coated ambassador (18")				Batter: Remo coated ambassador Bottom: Remo clear ambassador							
Bearing Edge	60°R3											
Bass Drum Claw Hooks	Classic Claw Hooks (Concert BD type)						—					
TT mount	—			—			YES					
FT bracket	—				Vertical type w/ wing bolt				—			
BD leg	Absolute type											





### Swirl Orange set

Shell: CCB2015 CCF1413 CCT1208 CCS1455  
 Hardware: FP8500B HS1200 CS755 x 3 SS950 DS840 CL945LB



### Swirl Black set

Shell: CCB2415R CCF1816 CCF1615 CCT1208 CCS1455  
 Hardware: FP8500B HS1200 CS755 x 3 SS950 x 2 DS840



#### Small Lugs

Separate type small lugs minimize contact between the shell and lug so the shell can vibrate freely, maximizing its sonic potential.



#### Triple Flange Hoops (1.6mm)

1.6mm triple flange hoops deliver a more open sound.

### Color Finishes



Swirl Orange



Swirl Black



Swirl Blue



Black Wood



Dark Wood



Air-Seal System



Kapur Shell



Universal Size (BD)



BD/FT/TT 6-ply



Small Lug (Chrome)



Lug Insertion plate



Triple flange (Steel / 1.6mm)



YESS (TT)



YESS (FT)



Bass Drum Legs



Floating BD System



R-Version BD



P3 Smooth White



Remo Clear P3



Remo Coated Ambassador



Remo Coated Ambassador



Remo Clear Ambassador

# OAK CUSTOM

## Played Loud, Played Heavy These Drums Respond

The introduction of the Oak Custom by Yamaha sent a shudder through the drum industry. For low end that shakes the floors, crisp highs that penetrate, and mids that ring through the mix, insist on the power of oak.



### Red Sparkle Set

#### Shells

NBD824UA NTT812UA  
NFT816A NSD1470(HSS)  
NFT814A

\*Cymbals and Hardware (except Tom holder/Tom clamp) are not included.



### Black Sparkle Sunburst Set

#### Shells

NBD822UA X 2 NTT812UA  
NFT816A NTT810UA  
NFT814A NSD1470

\*Cymbals and Hardware (except Tom holder/Tom clamp) are not included.

# Shake It Up With Yamaha Oak

Yamaha is the only drum manufacturer bringing the full potential of oak to a drum kit. From the punchy resonant lows of the bass drum to a snare that bites and toms that cut through, the power of oak definitely shakes things up.

## Oak Lugs

Oak custom drums feature newly designed lugs with small footprints and single-bolt attachment that minimize surface contact and maximize shell resonance and sustain. A nylon insert holds tension rods in place under heavy play.

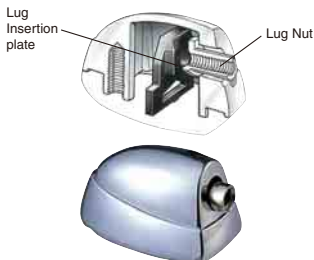

## Bass Drum Legs

Holdig these powerful drums in place are our Absolute series bass drum legs. Large pipes are Yamaha engineered for greater durability and stability. Spurs slide in and out with a handy knob that also shows spur position at a glance, and a standard drum hey locks spures and height adjustment in place.



## Color Finishes

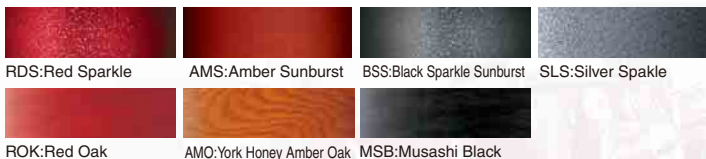

Oak Custom drums are available in seven high-gloss finishes. Amber Sunburst, Red Oak, Musashi Black and York Honey Amber Oak are translucent hues that bring out the distinctive beauty of the wood grain, while Red Sparkle, Silver Sparkle and Black Sparkle Sunburst glitters under lights, epitomizing a vintage look.

Bass Drums		<b>24"</b>	<b>22"</b>	<b>20"</b>	<b>18"</b>	<input type="checkbox"/> Depth
	Universal Size	[17"]NBD824UA	[17"]NBD822UA	[17"]NBD820UA	[15"]NBD818UFA	*R-Version is available for BD of 20"-24"

Floor Toms		<b>18"</b>	<b>16"</b>	<b>14"</b>
	Power Size	[16"]NFT818A	[16"]NFT816A	[14"]NFT814A

Mounted Toms		<b>16"</b>	<b>14"</b>	<b>13"</b>	<b>12"</b>	<b>10"</b>	<b>8"</b>
	Standard Size	—	—	—	—	—	[7"]NTT808JA
	Universal Size	—	—	[10"]NTT813UA	[9"]NTT812UA	[8"]NTT810UA	—
	Power Size	[14"]NTT816A	[12"]NTT814A	—	—	—	—

## Set Configuration

Set No.	Individual Package Contents	Bass Drum Mounted Tom	Floor Tom Mounted Tom	Tom Holder	Tom Clamp
NY2FS4A	NY2FS41A	NBD822UA	NFT816A	—	—
	NY2FS42A	NTT812UA	NTT810UA	TH945B	—
NY2T4A	NY2T41A	NBD822UA	NTT814A	—	—
	NY2T42A	NTT812UA	NTT810UA	TH945B	CL945B
NY0T4A	NY0T41A	NBD820UA	NTT814A	—	—
	NY0T42A	NTT812UA	NTT810UA	TH945B	CL945B

**Air-Seal System**

**Shell**

**Universal Size (BD)**

**Hoop DynaHoop(Steel / 2.3mm) (TT/FT) Wood Hoop(BD)**

**Small Lug**

**Lock**

**Lug Insertion plate**

**YESS (TT)**

**YESS (FT)**

**Bass Drum Legs**

**Floating BD System**

**R-Version BD**

**Remo Ebony Power Stroke P3**

**Remo Power Stroke P3**

**Remo Coated Ambassador**

**Remo Clear Ambassador**

**Remo Clear Ambassador**

**All Round Ball Clamp (Short Rod)**

**Triple Tom Holder (Triple Hole)**



# ROCK TOUR

## Make Your First Shot Your Best Shot

If you have your sights set on becoming a rock drummer, it's important that the drums you are playing will help you reach your goal. Yamaha's Rock Tour Series are the perfect choice, delivering a solid, powerful sound with sharp attack that will cut through and get you noticed. Hardware and toms offer quality inherited from Yamaha's high-end drum kits, and the kits provide excellent durability and great cost performance. Rock Tour drums are available in three all-new finishes, any one of which will have you looking sharp on stage.

If you're ready to make your mark, check out the new Rock Tour drums and give it your best shot.



### Matte Blue Metallic (MUM)

RT2FM3M

■SHELLS RTB2218MR RTF1615M RTT1208M RTS1460M

\*Cymbals and Hardware (except Tom holder/Tom clamp) are not included.



### Textured Brown Sunburst (TWS)

RT2F3A

■SHELLS RTB2218AR RTF1615A RTT1208A RTS1460A

\*Cymbals and Hardware (except Tom holder/Tom clamp) are not included.



## Textured Green (TG)

RT2FA

■SHELLS RTB2218AR RTF1615A RTT1208A RTS1460A

\*Cymbals and Hardware (except Tom holder/Tom clamp) are not included.



## Badges

The embossed Yamaha logo design on the V-shaped Rock Tour series badges.



## Matte Hardware for Matte on Matte

Yamaha's Matte on Matte color schemes start with a metallic colored matte finish on the shells and compliment it with a matte silver finish on lugs and hoops.



## Textured Ash Finish

Applied painting technique from our top end model PHX is used to bring out the beautiful grain of the ash wood. This striking finish is available on the Rock Tour series in monotone and sunburst variations.

## Color Finishes



MSM:Matte Silver Metallic

MUM:Matte Blue Metallic

MBM: Matte Black Metallic



TS:Textured Smoke

TG:Textured Green

TW:Textured Brown

TR:Textured Red



TSS:Textured Smoke Sunburst

TGS:Textured Green Sunburst

TWS: Textured Brown Sunburst

TRS: Textured Red Sunburst

## Set Configuration

Size No.	Bass Drum	Floor Tom	Tom Tom
RT2F3M	RTB2218MR	RTF1615M	RTT1208M
RT2F3A	RTB2218AR	RTF1615A	RTT1208A

## Specifications

	Bass Drum	Floor Tom	Tom Tom		Snare Drum
Size (Diameter x Depth)	22"x18"	14"x13"	13"x9"	10"x7"	14"x6"
Model No.	RTB2218MR RTB2218AR	RTF1413M RTF1413A	RTT1309M RTT1309A	RTT1007M RTT1007A	RTS1460M RTS1460A





# Tour Custom

Maple Shell and Rounder Bearing Edge Deliver Rich Tone with Just the Right Amount of Sustain

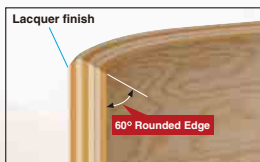

## All Shells 100% Maple \*

All maple shells give the Tour Custom drums its warm, bright tone. Shells are designed with a 60-degree R2 bearing edge that adds the tonal depth found in vintage drums and just the right amount of sustain. Finished with a high gloss lacquer (all new colors) maximizes the sonic potential of the maple shell creating drums that sound and play great in any musical style. \* Bass drum hoops are made of Maple and Philippine Mahogany



### Brown Sunburst

**TC2T5**  
■SHELLS  
TBD822U  
TTT814  
TTT812U  
TTT810U  
TSD0846

\*Cymbals and Hardware (except Tom holder/Tom clamp) are not included.



### Black Onyx

**TC2T5**  
■SHELLS  
TBD822U  
TTT814  
TTT812U  
TTT810U  
TSD0846

\*Cymbals and Hardware (except Tom holder/Tom clamp) are not included.





## Cranberry Red

**TC2T5**

■SHELLS  
 TBD822U  
 TTT814  
 TTT812U  
 TTT810U  
 TSD0846

\*Cymbals and Hardware (except Tom holder/Tom clamp) are not included.

## Natural Wood

**TC2FS5**

■SHELLS  
 TBD822U TTT812U TSD0846  
 TTT816 TTT810U



\*Cymbals and Hardware (except Tom holder/Tom clamp) are not included.

## Color Finishes



NW: Natural Wood



RBS: Red Black Sunburst



CR: Cranberry Red

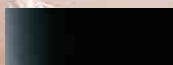

BKO: Brack Onyx



BRS: Brown Sunburst

## Set Configuration

Set No.	Individual Package Contents	Bass Drum Mounted Tom	Floor Tom Snare Drum	Mounted Tom/Snare Drum	Tom Holder/Tom Clamp
TC2FS5	TC2FS51	TBD822U	TFT816	TTT810U	TH945B
	TC2FS52	TTT812U	TSD0846	—	—
TC2F4	TC2F41	TBD822U	TFT816	—	CL945LB
	TC2F42	TTT812U	TSD0846	—	—
TC2T5	TC2T51	TBD822U	TTT812U	TSD0846	CL945LB
	TC2T52	TTT810U	TTT814	—	TH945B

## Bass Drums

	24"	22"	20"	18"
Universal Size	17" TBD824U	17" TBD822U	17" TBD820U	15" TBD818U
Power Size	—	—	—	—

## Floor Toms

	18"	16"	14"
—	—	—	—
16"	TFT818	16" TFT816	14" TFT814

## Mounted Toms

	16"	14"	13"	12"	10"	8"	14"	Depth
Standard Size	—	—	—	—	—	7" TTT808J	—	—
Universal Size	—	—	10" TTT813U	9" TTT812U	8" TTT810U	—	—	—
Power Size	14" TTT816	12" TTT814	—	—	—	—	6" TSD0846	—

## Snare

Air-Seal System	Shell	Universal Size (BD)	Triple Flange Hoop (Steel / 1.5mm)	Separate Lug	YESS (TT)	YESS (FT)	Bass Drum Spurs	Remo UK Ebony Power Stroke P3	Remo UK Clear Power Stroke P3	Remo UK Clear Ambassador	Remo UK Clear Ambassador

— Hardware —

All Round Ball Clamp (Short Rod)	Triple Tom Holder

# STAGE CUSTOM

## ALL BIRCH SHELL

100% Birch Shell Stage Custom has evolved again

As with the introduction of Stage Custom in 1995 YAMAHA once again sets the standards of value and sound.

By borrowing from our legendary Recording Custom drums, we are proud to introduce new 100% Birch Shell Stage Custom.



### Shell

The shell is a key factor in a drum's ability to "rumble," or resonate. Accordingly, the Stage Custom employs 100% birch - a classic in the realm of high-class drum kits. Moreover, with its six-ply structure the Stage Custom accurately conveys the vibrations produced at the impact surface, achieving performance that overwhelms anything in its class.



ALL BIRCH 6PLY

- 1 Boom Cymbal Stands adopt a new boom tilter design for improved stability and adjustability.
- 2 A center tilter that can be set for highly accurate cymbal positioning and player articulation.
- 3 The YESS specification floor-tom bracket, incorporating a wing bolt.
- 4 Improved snare basket mechanism.



### Sapphire Blue (SB)

#### ■ SCB2FS51

BBD622U  
BFT616  
BTT610U  
BSD0655  
TH945B

#### ■ SCB12HW

BTT612U  
CS755 x 2  
HS740A  
SS740A  
FP7210A





### Natural Wood (NW)

- SCB0F51
- SCBHW12
- BBD620U
- BTT612U
- BFT614
- CS755 x 2
- BTT610U
- HS740A
- TH945B
- SS740A
- BSD0655
- FP7210A



### Cranberry Red (CR)

- SCB8F3
- HW680
- BBD618U
- CS655A x 2
- BFT614U
- HS650A
- BTT610J
- SS650A
- BSD0655
- FP6110A
- CL945LB

### Color Finishes



\*"SCB8F3" color only Natural Wood and Cranberry Red.

### Bass Drums

24"	22"	20"	18"	<input type="checkbox"/> : Depth
17" BBD624U	17" BBD622U	17" BBD620U	15" BBD618U	

### Floor Toms

18"	16"	14"
16" BFT618	16" BFT616	14" BFT614

### Mounted Toms

16"	14"	13"	12"	10"	8"
14" BTT616	12" BTT614	10" BTT613U	9" BTT612U	8" BTT612J	8" BTT610U
					7" BTT608J

### Set Configuration

Set No.	Individual Package Contents	Bass Drum Mounted Tom	Floor Tom Cymbal Stand	Tom Tom Hi-Hat Stand	Tom Holder/Tom Clamp Snare Stand	Snare Drum Foot Pedal
SCB2FS5	SCB2FS51	BBD622U	BFT616	BTT610U	TH945B	BSD0655
	SCBHW12	BT612U	CS755x2	HS740A	SS740A	FP7210A
SCB0F5	SCB0F51	BBD620U	BFT614	BFT610U	TH945B	BSD0655
	SCBHW12	BTT612U	CS755x2	HS740A	SS740A	FP7210A
SCB8F3	—	BBD618U	BFT614U	BTT612J	CL945LB	—
HW680	(Recommend)	CS655Ax2	HS650A	SS650A	FP6110A	—

Shell  
 Triple Flange Hoop (Steel / 1.6mm) (FT/TT) Wood Hoop(BD)  
 Separate Lug  
 Unlock Lug Nut  
 YESS (TT)  
 YESS (FT)  
 Bass Drum Legs  
 Yamaha Black Ambassador  
 Yamaha Clear Ambassador  
 Yamaha Clear Ambassador  
 Yamaha Clear Diplomat  
 BD (Front)  
 BD (Batter)  
 FT/TT (Top)  
 FT/TT (Bottom)

— Hardware —  
 All Round Ball Clamp (Short Rod)  
 Triple Tom Holder

# GIGMAKER

Play your next gig in style...  
on your very own set  
of Yamaha Drums

## GM2F5

GM2F51  
BD22"x16" / FT16"x16" /  
TT12"x9" / Tom Holder

GM2F52  
TT13"x9.5" / SD14"x5.5"

GM2F53  
CS651WA / SS650WA /  
HS650WA / FP6110A



## GM0F5

GM0F51  
BD20"x16" / FT14"x14" /  
TT10"x8" / TomHolder

GM0F52  
TT12"x9" / SD14"x5.5"

GM2F53  
CS651WA / SS650WA /  
HS650WA / FP6110A





## Feature

### Tom Holder

The GIGMAKER drum kit features Yamaha's exclusive ball mount and clamp tom holders that let you easily set the drum's head to any angle with a single bolt.

This unique system delivers excellent stability and outstanding durability as well.



### Glitter Finish

GIGMAKER drum shells feature glitter color finishes like those on our high-end drum kits.

The finishes are available in five different colors.



### Seamless Hoop

GIGMAKER by Yamaha implements extruded hoop manufacturing technology ensuring consistency and tuning stability.



### Wood Hoop (Bass Drum)

Bass drums fitted with wood hoops produce a warmer tone along with powerful presence and greater expression.



### Hardware

Durability and flexibility make Yamaha hardware second-to-none for touring professionals in every corner of the globe. Yamaha 600 series hardware features locking resin cymbal tilters with extra-large felts, a professional grade HH clutch and maximum tolerance nylon-belt kick pedals.

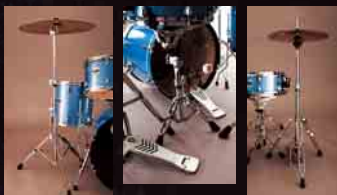

## Environment & Quality

### Environmentally Friendly Design (Formaldehyde Standard)

Formaldehyde, which is used in adhesives for wood, has been linked to allergies. At Yamaha, we have put in place a group-wide program aimed at reducing the use of formaldehyde in our products. In line with this we are improving equipment, adhesives, processing conditions, etc., in our drum manufacturing process. GIGMAKER drums exceed standards set in both Germany and Japan, which are considered the world's most stringent to date, and comply with CARB (California Air Resources Board) regulations in California, U.S.A.

### Yamaha Quality

At Yamaha, we believe that entry-level models should deliver a fundamental level of performance and deliver a satisfying experience both playing and musically. Just like our high-end drum kits, GIGMAKER drums must pass strict quality standards. No kit is allowed to leave the factory without clearing a number of quality checks that include tone quality, sound output, hardware stability and durability.

### Color Finishes



Burgundy Glitter

Blue Ice Glitter

White Grape Glitter

Silver Glitter

Black Glitter

Black

### Set Configuration

GM2F5	GM2F51	BD 22"x16"	FT 16"x16"	TT 12"x9"	THGM
	GM2F52	TT 13"x9 1/2"	SD 14"x5 1/2"	-	-
	GM2F53A	CS651W	HS650W	SS650W	FP6110
GM0F5	GM0F51	BD 20"x16"	FT 14"x14"	TT 10"x8"	THGM
	GM0F52	TT 12"x9"	SD 14"x5 1/2"	-	-
	GM2F53A	CS651W	HS650W	SS650W	FP6110

### Specifications

	BassDrum	FloorTom	TomTom	SnareDrum
Shell	7ply	6ply		
Hoop	Wood	Steel 1.5mm		
Head	Clear with Yamaha logo			Coated
Lug	Separate lug			
Mount	TH type			

# Specifications

		Components	Bass Drums					Flo
		Diameter	26"	24"	22"	20"	18"	18"
PHX Series	Size	xDepth Model No.	—	x16" PHXB2416(R)	x16" PHXB2216(R)	x16" PHXB2016(R)	x14" PHXB1814	x16" PHXF1816
		xDepth Model No.	—	x18" PHXB2418(R)	x18" PHXB2218(R)	x18" PHXB2018(R)	—	
Absolute Series (Maple Custom)	Size	xDepth Model No.	—	x16" MAB2416/H	x16" MAB2216/H	x16" MAB2016/H	x14" MAB1814/H	x16" MAF1816/H
		xDepth Model No.	—	x18" MAB2418/H	x18" MAB2218/H	x18" MAB2018/H	x14" MAB1814F/HF	—
		xDepth Model No.	—	x18" MAB2418R/HR	x18" MAB2218R/HR	x18" MAB2018R/HR	—	—
		xDepth Model No.	—	—	x20" MAB2220/H	—	—	—
		xDepth Model No.	—	—	x20" MAB2220R/HR	—	—	—
Absolute Series (Birch Custom)	Size	xDepth Model No.	—	x16" BAB2416/H	x16" BAB2216/H	x16" BAB2016/H	x14" BAB1814/H	x16" BAF1816/H
		xDepth Model No.	—	x18" BAB2418/H	x18" BAB2218/H	x18" BAB2018/H	x14" BAB1814F/HF	—
		xDepth Model No.	—	x18" BAB2418R/HR	x18" BAB2218R/HR	x18" BAB2018R/HR	—	—
		xDepth Model No.	—	—	x20" BAB2220/H	—	—	—
		xDepth Model No.	—	—	x20" BAB2220R/HR	—	—	—
Recording Custom	Standard Size	xDepth Model No.	x14" BD926YJ	x14" BD924YJ	x14" BD922YJ	x14" BD920YJ	x14" BD918YJ	—
	Power Size	xDepth Model No.	—	x16" BD924Y	x16" BD922Y	x16" BD920Y	—	x16" FT918Y
Club Custom	Size	xDepth Model No.	—	—	x15" CCB2215	x15" CCB2015	x15" CCB1815	x16" CCF1816
		xDepth Model No.	—	x15" CCB2415R	x15" CCB2215R	x15" CCB2015R	—	—
Oak Custom	Size	xDepth Model No.	—	x17" NBD824UA	x17" NBD822UA	x17" NBD820UA	x15" NBD818UFA	x16" NFT818A
		xDepth Model No.	—	x17" NBD824UAR	x17" NBD822UAR	x17" NBD820UAR	—	—
Rock Tour	Size	xDepth Model No.	—	—	x18" RTB2218MR	—	—	—
		xDepth Model No.	—	—	x18" RTB2218AR	—	—	—
Tour Custom	Standard Size	xDepth Model No.	—	—	—	—	—	—
	Universal Size	xDepth Model No.	—	x17" TBD824U	x17" TBD822U	x17" TBD820U	x15" TBD818U	—
	Power Size	xDepth Model No.	—	—	—	—	—	x16" TFT818
Stage Custom	Standard Size	xDepth Model No.	—	—	—	—	—	—
	Universal Size	xDepth Model No.	—	x17" BBD624U	x17" BBD622U	x17" BBD620U	x15" BBD618U	—
	Power Size	xDepth Model No.	—	—	—	—	—	x16" BFT618
GIGMAKER	Power Size	xDepth	—	—	x16"	x16"	—	—



Door Toms		Mounted Toms						
16"	14"	16"	15"	14"	13"	12"	10"	8"
x15" PHXF1615	x13" PHXF1413	x13" PHXT1613	—	x11" PHXT1411	x9" PHXT1309	x8" PHXT1208	x7" PHXT1007	x7" PHXT0807
		x14" PHXT1614	—	x12" PHXT1412	x10" PHXT1310	x9" PHXT1209	x8" PHXT1008	x8" PHXT0808
x15" MAF1615/H	x13" MAF1413/H	x13" MAT1613/H	—	x11" MAT1411/H	x9" MAT1309/H	x8" MAT1208/H	x7" MAT1007/H	x7" MAT0807/H
—	—	x14" MAT1614/H	—	x12" MAT1412/H	x10" MAT1310/H	x9" MAT1209/H	x8" MAT1008/H	—
—	—	—	—	—	—	—	—	—
—	—	—	—	—	—	—	—	—
—	—	—	—	—	—	—	—	—
x15" BAF1615/H	x13" BAF1413/H	x13" BAT1613/H	—	x11" BAT1411/H	x9" BAT1309/H	x8" BAT1208/H	x7" BAT1007/H	x7" BAT0807/H
—	—	x14" BAT1614/H	—	x12" BAT1412/H	x10" BAT1310/H	x9" BAT1209/H	x8" BAT1008/H	—
—	—	—	—	—	—	—	—	—
—	—	—	—	—	—	—	—	—
—	—	—	—	—	—	—	—	—
—	—	—	x12" TT915YJ	x10" TT914YJ	x9" TT913YJ	x8" TT912YJ	x7 1/2" TT910YJ	—
x16" FT916Y	x14" FT914Y	x14" TT916Y	x13" TT915Y	x12" TT914Y	x11" TT913Y	x10" TT912Y	x9" TT910Y	x8" TT908Y
x15" CCF1615	x13" CCF1413	—	—	—	x9" CCT1309	x8" CCT1208	x7" CCT1007	x7" CCT0807
—	—	—	—	—	—	—	—	—
x16" NFT816A	x14" NFT814A	x14" NTT816A	—	x12" NTT814A	x10" NTT813UA	x9" NTT812UA	x8" NTT810UA	x7" NTT0808JA
—	—	—	—	—	—	—	—	—
x15" RFT1615M	x13" RFT1413M	—	—	—	x9" RTT1309M	x8" RTT1208M	x7" RTT1007M	—
x15" RFT1615A	x13" RFT1413A	—	—	—	x9" RTT1309A	x8" RTT1208A	x7" RTT1007A	—
—	—	—	—	—	—	—	—	x7" TTT808J
—	—	—	—	—	x10" TTT813U	x9" TTT812U	x8" TTT810U	—
x16" TFT816	x14" TFT814	x14" TTT816	—	x12" TTT814	—	—	—	—
—	—	—	—	—	—	—	x7 1/2" BTT610J	x7" BTT608J
—	x14" BFT614U	—	—	—	x10" BTT613U	x9" BTT612U	x8" BTT610U	—
x16" BFT616	x14" BFT614	x14" BTT616	—	x12" BTT614	—	—	—	—
x16"	x14"	—	—	—	x9 1/2"	x9"	x8"	—

# Set Configuration

## Absolute Series

	Set No.	BD	FT	TT	Hardware
Maple Custom (Absolute Lug)	MA2F2	MAB2218	MAF1615	—	TH945B
	MA2RF2	MAB2220R	MAF1615	—	—
	MA2RT2	MAB2218R	—	MAT1412	—
	MA0F2	MAB2016	MAF1413	—	TH945B
	MAT2	—	—	MAT1209, MAT1008	—
Maple Custom (Hook Lug)	MAH2F2	MAB2218H	MAF1615H	—	TH945B
	MAHT2	—	—	MAT1209H, MAT1008H	—
Birch Custom (Absolute Lug)	BA2F2	BAB2218	BAF1615	—	TH945B
	BA2RF2	BAB2220R	BAF1615	—	—
	BA2RT2	BAB2218R	—	BAT1412	—
	BA0F2	BAB2016	BAF1413	—	TH945B
	BAT2	—	—	BAT1209, BAT1008	—
Birch Custom (Hook Lug)	BAH2F2	BAB2218H	BAF1615H	—	TH945B
	BAHT2	—	—	BAT1209H, BAT1008H	—

## Recording Custom

Set No.	Individual Package Contents	BD	FT	—	—
		TT	TT	Tom Holder	Tom Clamp
RY2F4	RY2F41	BD922Y	FT916Y	—	—
	RY2F42	TT912Y	TT913Y	TH945B	—
RY2T4	RY2T41	BD922Y	TT914Y	—	—
	RY2T42	TT910Y	TT912Y	TH945B	CL945B
RY0T4	RY0T41	BD920Y	TT914Y	—	—
	RY0T42	TT910Y	TT912Y	TH945B	CL945B

## Oak Custom

Set No.	Individual Package Contents	BD	FT	—	—
		TT	TT	Tom Holder	Tom Clamp
NY2FS4A	NY2FS41A	NBD822UA	NFT816A	—	—
	NY2FS42A	NTT812UA	NTT810UA	TH945B	—
NY2T4A	NY2T41A	NBD822UA	NTT814A	—	—
	NY2T42A	NTT812UA	NTT810UA	TH945B	CL945B
NY0T4A	NY0T41A	NBD820UA	NTT814A	—	—
	NY0T42A	NTT812UA	NTT810UA	TH945B	CL945B

BD= Bass Drum, FT= Floor Tom, TT= Tom Tom, SD= Snare Drum

# Set Configuration

## Rock Tour

Set No.	BD	FT	TT	Recommended H/W
RT2F3M	RTB2218MR	RFT1615M	RTT1208M	HW780
RT2F3A	RTB2218AR	RFT1615A	RTT1208A	CSAT924A CL945B

## Tour Custom

Set No.	Individual Package Contents	BD	FT	TT/SD	Tom Holder/ Tom Clamp	Recommended H/W
		TT	SD	—	Tom Clamp	
TC2FS5	TC2FS51	TBD822U	TFT816	TTT810U	TH945B	HW780
	TC2FS52	TTT812U	TSD0846	—	—	
TC2F4	TC2F41	TBD822U	TFT816	—	CL945LB	HW780
	TC2F42	TTT812U	TSD0846	—	—	
TC2T5	TC2T51	TBD822U	TTT812U	TSD0846	CL945B	HW780 CSAT924A
	TC2T52	TTT810U	TTT814	—	TH945B	

## Stage Custom

Set No.	Individual Package Contents	BD	FT	Tom Clamp/ Hi-Hat Stand/ TT	SD/ Snare Stand Tom Holder	Foot Pedal
		TT	Cymbal Stand			BD
SCB2FS5	SCB2FS51	BBD622U	BFT616	BTT610U	TH945B	BSD0655
	SCB12HW	BTT612U	CS755x2	HS740A	SS740A	FP7210A
SCB0F5	SCB0F51	BBD620U	BFT614	BTT610U	TH945B	BSD0655
	SCB12HW	BTT612U	CS755x2	HS740A	SS740A	FP7210A

## GIGMAKER

Set No.	Individual Package Contents	BD	FT	TT	Tom Holder
		TT	SD	—	—
		CS	Hi-Hat Stand	Snare Stand	Foot Pedal
GM2F5	GM2F51	BD 22"x16"	FT 16"x16"	TT 12"x9"	THGM
	GM2F52	TT 13"x9 1/2"	SD 14"x5 1/2"	—	—
	GM2F53A	CS651W	HS650W	SS650W	FP6110
GM0F5	GM0F51	BD 20"x16"	FT 14"x14"	TT 10"x8"	THGM
	GM0F52	TT 12"x9"	SD 14"x5 1/2"	—	—
	GM2F53A	CS651W	HS650W	SS650W	FP6110

## Hardware Set

HW880	CS865 x2	HS850	SS850	FP9500C
HW780	CS755 x2	HS740A	SS740A	FP7210A
HW680	CS655A x2	HS650A	SS650A	FP6110A
HW680W	CS665A x2	HS650WA	SS650WA	FP7210A

# Rick Marotta Signature Hippig

The Rick Marotta Signature Hippig offers drummers a complete kit that can be packed into Bass Drum for easy transport. When setup two toms, the snare drum and two cymbals all attach to the bass drum by means of three pipe clamps. When packed up, the two tom toms and the snare drum fit neatly into the two-piece bass drum. The bass drum fits into separate soft case, for transport. All drums are fitted with special Remo heads. For performance that is hard to believe, in a kit as compact as this, take a close look at your nearest Yamaha dealer.



*Rick Marotta*

## Add-On\* 8" and 12" Toms Provide the Hippig with Greater Expressive Power and Versatility.

\*Sold separately



**TT08HGARM**  
size : 8" x 5 1/2"



\* Soft case supplied.  
The tom will not fit inside the bass drum.



**TT12HGARM**  
size : 12" x 6 1/2"



\* Soft case supplied.  
The tom will not fit inside the bass drum.

### ■ HG6T41ARM Shell Set

- BD16HGARM
- TT13HGARM
- TT10HGARM
- SD12HGARM
- BD Soft Casex1
- TT,SD Soft Casex1



CHERRY WOOD

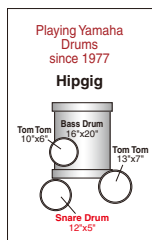
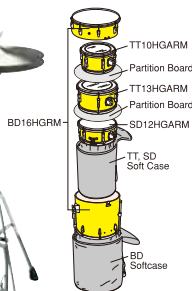

\* Cymbals & Hardware are not included.  
\* This model is sold as a set only. Individual components are not sold separately.



**Air-Seal System**



**Birch/Philippine Mahogany**



**7-ply**



**BD**



**FT, TT, SD Separate Lug (BD/FT/TT)**



**One-piece Lug (SD)**



**U-nut**



**Triple flange (Steel / 1.6mm)**



**TT MOUNT**



**Pipe Clamp**



**Bass Drum Spurs**



**Floating BD System**



**Remo Renaissance Power Stroke 3**



**Remo Renaissance Power Stroke 3**



**Remo Pinstripe**



**Remo Clear Ambassador**



**Remo Clear Ambassador**



**Remo Ambassador Coated**



**Remo Ambassador Snare**



**Remo Ambassador Snare**



**All Round Ball Clamp (Long Rod)**

### Recommended Hardware

- DS750 x 1
- HS650A x 1
- TH904A x 1
- CL940B x 1
- CL940LB x 2
- CH755 x 2
- FP7210A x 1
- PPC4A x 1

### ● Specification

	Bass Drum (Separate type)	Mounted Toms		Snare Drum
Shells	Birch & Philippine Mahogany 7-ply			
Size (DiameterxDepth)	16"x20"	13"x7"	10"x6"	12"x5"
Hoops	Triple flange steel (1.6mm)			
No. of Tuning Bolts	8	6	6	6



*Al Foster*

# Al Foster Signature Hippig Sr.

## Larger Diameters Offer Greater Performance

Compared to the original Hippig, drum diameters on the new Hippig Sr. have all been increased to offer drummers greater tone and performance in a still compact, easy to transport drum kit. The bass drum diameter has increased two inches, from the original 16 inches to 18, while the 14 and 12 inch tom toms and the 13 inch snare are all one-size larger than before. The 7-ply shells are made of Birch and Philippine Mahogany using our original Air-Seal System.



JAGUAR PATTERN



**TT10HGAL**  
size : 10" x 6 1/2"  
(Sold Separately)

\* Soft case supplied. The tom will not fit inside the bass drum.

### Hippig SR. Set ■ HG8T41AL

**Shell Set**  
BD18HGAL  
TT14HGAL  
TT12HGAL  
SD13HGAL

BD Soft Casex1  
TT, SD Soft Casex1  
Hardware Soft Casex1  
DS750

\* CL940LB x 3 are necessary to mount SD & Toms on BD.

\* Cymbals & Hardware are not included.  
\* This model is sold as a set only. Individual components are not sold separately.

### COLOR FINISHES

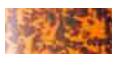

JGR :  
JAGUAR PATTERN



WMP :  
WHITE MARINE PEARL

### ● Specification

	Bass Drum (Separate type)	Mounted Toms		Snare Drum
Shells	Birch & Philippine Mahogany 7-ply			
Size (DiameterxDepth)	18"x22"	14"x8 1/2"	12"x6 1/2"	13"x5"
Hoops	Triple flange steel (1.6mm)			
Head	Top	Remo Renaissance Power Stroke 3 (Batter)	Remo Ambassador Coated	Remo Ambassador Coated
	Bottom	Remo Renaissance Power Stroke 3 (Front)	Remo Clear Ambassador	Remo Ambassador Snare

# club Jordan COCKTAIL DRUM SYSTEM

## Club Cocktail Drum System



### Club Cocktail Drum System

■ **CD-15CJ**  
CJ cocktail drum, 15" x 24", 8 lugs, includes reverse foot pedal w/attachment, cymbal arm (accommodates cowbell, woodblock, closed hi-hats, and a cymbal), and percussion board

■ **FP-810CD**  
Cocktail drum reverse foot pedal

■ **FP-B**  
Cocktail drum reverse foot pedal bracket assembly

■ **CD-BOARD**  
CJ percussion board, 7-ply natural birch shell, includes brackets (fits 14", 15", and 16" 8-lug toms)



SLS :  
Silver Sparkle



PKS :  
Pink Sparkle



■ **TT-10CJ**  
CJ tom, 10" x 5", 6 lugs, includes L-arm mounting, YESS mounting bracket (mounts directly to main drum)



■ **SD-08CJ**  
CJ snare drum, 8" x 5", 5 lugs, includes L-arm, YESS mounting bracket (mounts directly to main drum)



# Manu Katché Signature JUNIOR KIT

"True power is not always revealed visually."

## Junior Kit (2 packages)

### ■ JK6F4AMK

BD16AJKMK  
FT13AJKMK  
TT10AJKMK  
SD12AJKMK  
CL940LB

### ■ JK6F42DMK

CS651Ax2  
SS652  
HS650A  
FP6210A  
DS550U

Silver



\* Cymbals are not included.  
\* This model is sold as a set only.  
Individual components are not sold separately.

## A Compact Drum Kit That's Great For Kids

"Why don't you make a real drum kit for kids?" That request by Manu Katché caught our designer's ears and had them designing this new compact drum kit. Compact, it is designed for kids but it is far from being a toy. A 16"x16" 9-ply bass drum with a 6-ply 13"x12" floor tom, 10"x7" tom and 12"x5" snare are all made of quality Philippine Mahogany using our original Air Seal System to produce shells that are perfectly round. Compact and easily transportable, these drums deliver tone that is so unbelievably real you might just be tempted to use it on gigs of your own.

Playing Yamaha Drums since 1988

### Manu Katché JUNIOR KIT

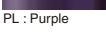
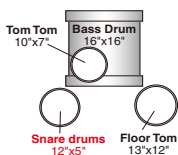

## ● Specification

		Bass Drum	Floor Tom	Mounted Tom	Snare Drum
Shells		Philippine Mahogany 9-ply	Philippine Mahogany 6-ply		
Size (DiameterxDepth)		16"x16"	13"x12"	10"x7"	12"x5"
Hoops		Triple flange steel (1.6mm)			
Head	Top	Remo UK Clear Power Stroke 3 (Batter)	Remo UK Coated		Remo UK Coated
	Bottom	Remo UK Ebony Power Stroke 3 (Front)	Remo UK Clear		Remo UK Snare



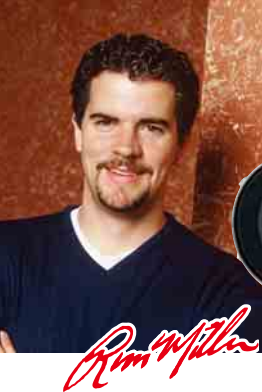

Low Frequency Capture Device

# SUBKICK



SKRM100

**Russ Miller's idea put into reality. Large diameter diaphragm captures bass drum sub-frequencies.**

The SUBKICK consists of a 10" x 5" birch and Philippine mahogany 7-ply shell that houses a 16cm, 50-watt low-frequency driver cone that acts as a diaphragm for this sub-frequency capture device. While its large diameter enables the SUBKICK to capture the natural low frequencies produced by the bass drum it can be used in tandem with a standard kick mic setup, to deliver an extremely powerful bass drum tone. The SUBKICK also works effectively with a floor tom, bass guitar, low brass, etc.

### Positioning Produces a Wide Range of Tonal Variations

Varying placement and proximity of the Subkick affects the nature of the sound captured, opening the door to a wide range of tonal possibilities. Try it directly in front of the sound hole or from various distances in front of the head to "dial in" degrees of ambience, punch, and volume. The Subkick works equally well in the studio and live.

### Specialty Designed Stand Offers Versatile Placement

The three-legged stand and ball clamp offer excellent stability and durability while the ball clamp offers versatile placement and angle adjustment of the mic unit.

### SPECIFICATIONS

Model	SKRM100
Size	10"x5"
Shell	Birch & Philippine Mahogany 7-ply (w/ Rod Clamp)
Color Finish	Vintage Black
Hoop	Triple Flange Steel (1.6mm)
Lug (Tuning Bolts)	One-piece Lug (6)
Head (Top & Bottom)	Mesh Head
Type	Dynamic
Polar Pattern	Bi-directional
Output Jack	XLR-3-32 (cannon) jack
Weight	Main unit : 4kg, Stand : 3kg
Frequency Response	50Hz-2000Hz
Output Impedance	9Ω
Front Sensitivity	-47dB/ Bar (1kHz)

## Russ Miller Signature Wedges

L.A. session player, Russ Miller, was looking for a way to produce a cross stick sound from 12- and 13-inch snares when he came up with the idea for the Groove-Wedge. It attaches to the tuning bolts on most drums fitted with standard metal rims. The Groove-Wedge is designed for cross stick and rim shots while the Cascara-Wedge, which attaches in the same manner, functions as a percussion board.

Groove-Wedge RMGW



The all maple 19-ply Groove-Wedge easily attaches to most 8- to 15-inch drums fitted with standard metal rims. In addition to great rim shots it offers a wide variety of sonic possibilities.

Jingle-Wedge RMJW



The Jingle-Wedge fits on most 10- to 15-inch drums\* to add the timbre of a tambourine to the beat. It layers well with the sound of other drums and is also great for creating classic R&B backbeats when layered with the snare.

\*Excluding the YD Stage Custom Series 14-inch 6-hole drum.

Cascara-Wedge RMCW



The dancing Cuban cascara rhythm is usually played on the side of the floor tom. The cascara wedge fits most 10- to 18-inch drums. The 7-ply construction gives an authentic cascara tone while protecting drum shells from abrasion.

# Philosophy of the Yamaha Snare Drums

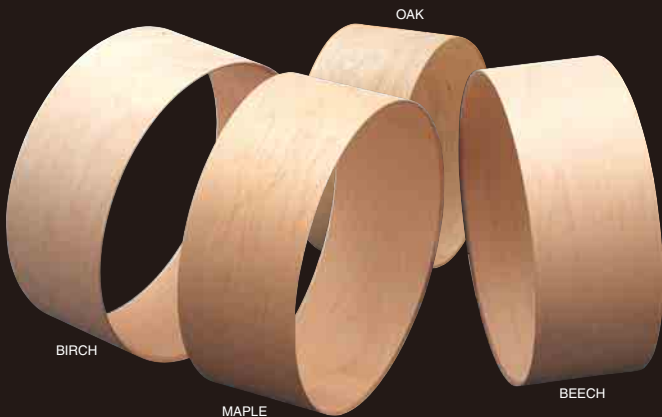

## Wood Shells



The sound of any drum starts with the shell. The creation of all Yamaha shells starts with the selection of the finest materials possible. Excellent woods are carefully selected and cut into plies and sealed together precisely with evenly distributed air pressure using our Air-Seal System. As a result every shell created with this process is in round and of uniform thickness to an incredibly perfect degree, and produces superior tone quality with exceptional durability.



## Metal Shells

Every Yamaha snare drum is in round and has a finely honed edge and carefully shaped snare bed. Steel shells are 1.2mm thick; brass and copper shells are 1.5mm thick; and aluminum shells are set at 2.0mm.

Brass shells deliver a rich, colorful tone with well-balanced definition through the dynamic range. Some say that brass lies between steel and wood in timbre. Versatile enough for concert settings, copper shell snare drums are characterized by sharp attack and strong low frequency response. Steel shell snare drums exhibit strong attack, a bright tone, and long and sustaining rim-shots. Aluminum shells offer a light, clean, and dry tone with plenty of body.



## Wood Hoops

Our 19-ply vintage wood hoops are crafted from select maple, specially coated with urethane for maximum durability. Wood hoops promote an organic sound characterized by good sustain. Rim-shots gain solidity and power simply not found with other hoops.

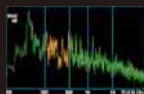

### Wood Hoop Waves

The power spectrum decreases smoothly from low frequency to high frequency ranges. Harmonic sounds are rich in middle frequency range (300-600Hz).

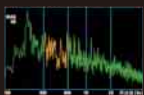

### Die-cast Hoops Waves

The power spectrum is low in middle frequency range and harmonic sounds in high frequency range (600-2,000Hz) is outstanding.

Zinc Die-cast  
(3.0mm)



Aluminium Die-cast  
(new type/3.0mm)



Triple flange Steel  
(1.6mm)



Dyna Hoop(2.3mm)

## Metal Hoops

The design and composition of the hoop play an important role in the sound of the snare drum, especially when executing rim-shots. Yamaha employs three types of metal hoops (steel, aluminum, and zinc) and two different manufacturing processes (roll forming and die-cast) in the production of four different hoop styles (see characteristics chart below).

The standard 1.6mm steel hoop can be used in all situations for a wide-open sound. The 2.3mm Dyna Hoop offers a sharper response and more solid rim-shots. Our 3.0mm zinc die-cast hoop firmly anchors the drumhead and delivers penetrating, full-bodied rim-shots. The 3.0mm Aluminum Die-Cast hoop provides many of the attributes of the Zinc hoop but without the extra-weight. Rim-shots are slightly more open, while attack and decay are magnified. Aluminum Die-Cast and Zinc Die-Cast hoops fix the head securely on the bearing edge. This precise head seating promotes natural tone and minimizes sound loss.

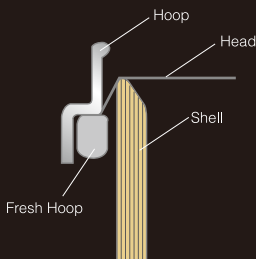

# Philosophy of the Yamaha Snare Drums

## Bearing Edge

In 40 years of product development, Yamaha has found four wood snare drum bearing edge designs that produce unique tonal character and depth. Sharp edges deliver sharper tone with excellent response and rounded angles produce a rounder, thicker tone. Varying the thickness of the radius top allows for further modification. Using different bearing designs on the top and bottom of the snare is also effective in modifying the tone.

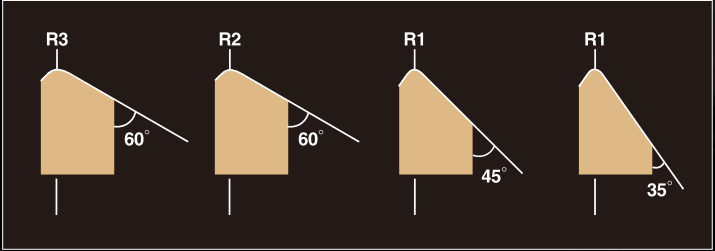

## Snare Bed

Snare bed depth greatly influences snare effectiveness making it the most important factor in creating the snare drum sound. Yamaha offers three snare bed types; a standard 1.8mm, a 2.7mm that offers greater snare sensitivity, and the 3.5mm used on the Steve Gadd Signature Snare Drum.







- Standard 1.8mm
- For Sensitive Sound 2.7mm
- For Staccato Sound 3.5mm

## Vent Holes

The number of vent holes in the shell has an impact on projection. The number of vent holes found in Yamaha snare drums will vary according to the type of tone being sought.

While the single hole is standard, a two-hole design like that used on the Sensitive Series, offers greater response, and the nine-hole design on the Loud Series delivers a crisp sound.



Model	Triple flange Hoop	DynaHoop	
Shape	 	 	
Material	Steel		
Thickness	1.6mm	2.3mm	
Method of manufacturing	Roll Forming		
Feature	Standard Hoop type	Ample thickness and heavy weight create a tight, sharp response.	Extra Crisp



## Sonic Hoop

### “Sonic Hoop Reinforcement Concept”

In the past, reinforcement hoops were used to compensate for inadequacies inherent to old shell designs that would often cause the shell to go out of round. Utilizing Yamaha's Air Seal System, it is virtually impossible for shells to go out of round. Our reasoning for using reinforcement hoops now is strictly a musical one. We utilize these hoops to bring out particular tonal characteristics, giving the drummer new and specific musical choices.

When a shell is being created via our Air Seal System, the Yamaha “Sonic Hoops” are being treated at the same time. In the end, this original process causes the hoops and shell to act as one unit as opposed to merely two pieces being glued together. This guarantees a sturdy reinforcement. Musically, it also produces a short sustain of the fundamental note, while also giving a rich and longer overtone.

Sonic Hoops can be found on the V-Series (VSD), Steve Jordan, and Andre Ceccarelli models.



Aluminum Die-cast Hoop	Zinc Die-cast Hoop	Wood Hoop
		
Aluminum	Zinc	Maple Wood
3.0mm	3.0mm	(19-ply)
Die-cast		Air Seal
Ordinary attack and decay creates a strong, tight sound		Fat, round sound, Rim shots are powerful and explosive.
to rim shots.	Crisp and deep rim shots.	

# Philosophy of the Yamaha Snare Drums

## Strainers

Yamaha strainers have undergone many design refinements. Today they are industry standards in terms of ergonomics, effectiveness, and quiet use. Fine snare adjustments are made with a central knob that allows small tension increments. Other adjustments are made with a drum key.

### Two-piece snare holding plate

Snare strings looped around the two plates are held securely in place and out of the way. (The two-piece snare holding plate is not employed on detachable strainer system.)

### Drum Key Tightening

A drum key secures snare strings to plates for quick operation and to ensure non-slip snare performance.

### Holding Plate Position

H type strainers are positioned closer to the shell to provide greater lifting power for superior snare to head contact.

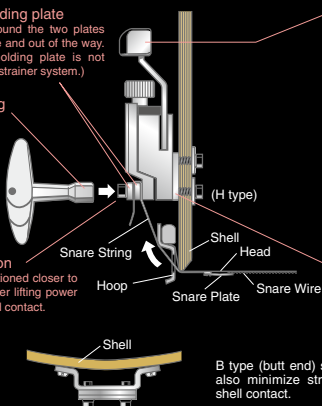

### Smooth Lever Operation

All Yamaha strainer levers are designed for ease of grip and liquid smooth operation. At rest, they lock reliably. G and H lever types are particularly smooth and feature finger-fitting contoured levers.

### Silicon Rubber

P and B type levers utilize a silicon rubber on the lock and lever parts for secure locking with quiet operation.

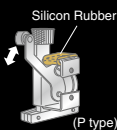

### Minimum Contact

Yamaha strainers are designed to contact the shell minimally, as are our butt plates, ensuring full shell vibration.

B type (butt end) strainers also minimize strainer to shell contact.

## Snares

Yamaha snare drums utilize two different basic snare types, stainless steel and hi-carbon steel, each possessing unique sonic characteristics. Strong nylon strings or woven filament tapes attach snare stands securely to strainer and butt plates.

### Snare Plate (Pat. Pend.)





Yamaha snare plates offer superior snare to head contact due to the slight bend in their design. When the string is drawn tight, the edge of the patented snare plate is pulled upward putting the snare in full contact with the head. Snare plates in the CP series are made using a special bonding agent between the plate and the coil that provides greater durability and finer response compared to previous designs. Snare coils on CP series snare drums are now covered with a special new finish that allows more of the material's tone to come through.

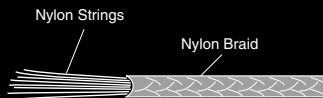

### Strong Snare Strings

Nylon strings are covered with a nylon braid for maximum strength and durability.



Side	Release Side					
Model	B type	H type	I type	IP type		
Shape	 B-5 type	 B-6 type	 B-8 type			



## Yamaha Snares

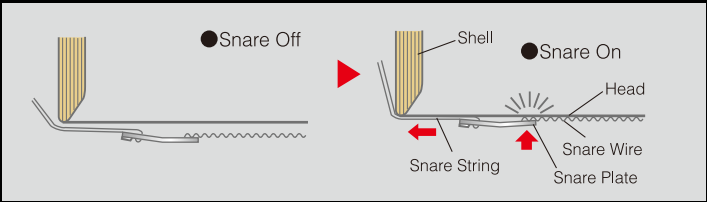

## Lugs

Our lugs incorporate special lug receiving units, not springs, for seating tuning rods securely. Nouveau Lugs on our Brass and Copper series snares employ a floating design that eliminates contact between lug casing and shell. The lug casing hitches only to a fixed shell bolt and can be snapped off for quick head changes. Our other more conventional lug casings are small in size, minimizing lug-to-shell contact, and incorporating nylon inserts that prevent tuning rods from loosening under heavy rimshots. Our high-tension one-piece lugs can accommodate heads tensioned to the limit.

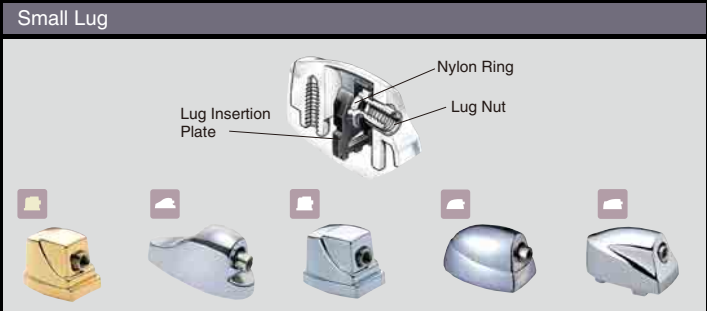
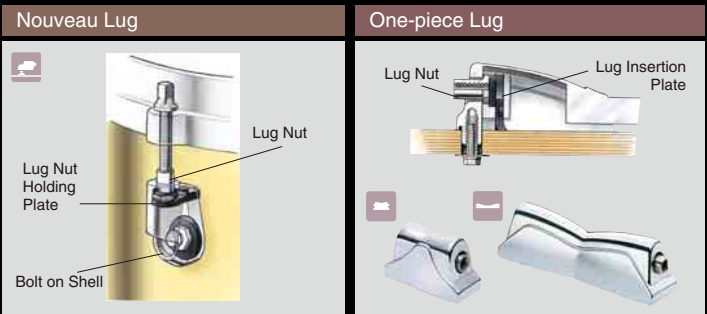

Butt Side					
P type	B type	DC type	G type	IP type	P type

# NEW CONCEPT SNARE

Capitalizing on 40 years of expertise in the manufacture of high-performance drums, we've completely renewed our series of standard-type snare drums. Every member of the YAMAHA series now has added the ability to express the characteristics unique to a range of musical genres, and to create sounds that suit any musical genre. This is the series with the sound you've been searching for.



## V-Series (VSD) "Vintage" Concept

To obtain the rich sound of a vintage snare drum suitable for any musical genre, the V-Series(VSD) incorporates a variety of specifications.

YAMAHA's original reinforced shell is equipped with a ring formed through the Airseal System, which is also used for the Airseal shell. The Vintage Finish process delivers maximum vibratory response in this series. The V-Series(VSD) is available in four visual themes, including new colors. The series features minimized lugs and bolts, as well as a slightly deeper snare head. These factors are there to bring out the amazing tonality you expect from YAMAHA. You'll feel and hear the difference from the various first beat.

## V-Series (VSD) "Vintage" Concept

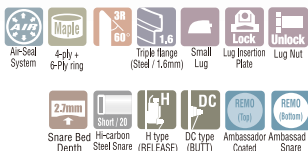

VSD1460 ■Size:14"x6"

### COLOR FINISHES



VN : Vintage Natural    VBK : Vintage Black  
VA : Vintage Apple    VBR : Vintage Brown

## L-Series (NSD) "Loud" Concept



NSD1455 ■Size:14"x5 1/2"

### COLOR FINISHES



MNO : Matte Natural OAK    MB : Musashi Black

ROK : Red OAK    SS : Solid Silver

BSS : Blue Sparkle Sunburst    BKSS : Black Sparkle Sunburst

HSS : Habanero Sparkle Sunburst    TS : Temple Silver

NSD1470 ■Size:14"x7"



## S-Series (MSD) "Sensitive" Concept

We have tuned the popular Maple Custom Series snare drum to produce even greater sensitivity and tonal control.

By carefully processing the top bearing edge to make it a rounder, 60-degree 2R edge, deeper fundamental tone has been brought out. Additionally, by giving the bottom rim a sharper angle of 45-degree 1R, the bottom head and the snare react more sensitively to each other. The greater depth of the bottom head contributes to that sensitivity.

## S-Series (MSD) "Sensitive" Concept

## L-Series (NSD) "Loud" Concept

This is a special drum using YAMAHA's original OAK material, which is highly regarded in the world of rock thanks to its massive volume and short decay.

Particularly, because nine vent holes release the excess air from the shell, the power of the snare drum concentrates on the backbeat. This system produces powerful bite and huge sound output.

The lug and hoop are all finished in black chrome. Setting the lug in an offset position provides a sharper image as well.



**MSD1455** ■Size:14"x5 1/2"







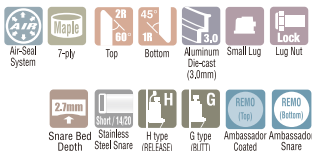

**MSD1465** ■Size:14"x6 1/2"



**MSD1365** ■Size:13"x6 1/2"



### COLOR FINISHES

	
AS : Amber Sunburst	TM : Turquoise Maple
	
CW : Cherry Wood	SB : Sea Blue
	
VN : Vintage Natural	AS : Antique Sunburst
	
BM : Black Maple	RPN : Red Pearl Natural

# YAMAHA CUSTOM SELECT SNARE DRUMS WOODEN SHELL

MAS1470



64 Solid Silver

BAS1460



59 White Grape Sparkle

MAS1440



61 Midnight Sky Blue

## Absolute (Maple Custom Absolute / Birch Custom Absolute)

■Size :14"x7"

■Size :Size:14"x6"

■Size :14"x4"

MAS1470, BAS1470

MAS1460(H), BAS1460(H)

MAS1440

### COLOR FINISHES

24 colors in total  
\*Refer to the color chart on page 11



CCS1455



## Club Custom

■Size :14"x5 1/2"

CCS1455

### COLOR FINISHES



Swirl Orange



Swirl Black



Swirl Blue



Black Wood



Dark Wood

NSD085A



## Oak Custom

■Size :14"x5.5"

All Oak 6-ply

NSD085A

### COLOR FINISHES



RDS: Red Sparkle



AMS: Amber Sunburst



BSS: Black Sparkle Sunburst



MSB: Musashi Black



AMO: York Honey Amber Oak



SLS: Silver Sparkle



ROK: Red Oak

## TSD0846

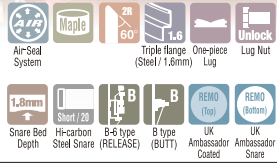

## Tour Custom

■Size :14"x6"

All Maple 6-ply

TSD0846

### COLOR FINISHES

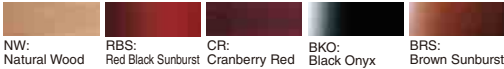

## BSD0655

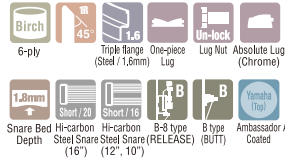

## BSD1250



## BSD1050



## Stage Custom Birch

■Size :14"x5 1/2"

■Size :12"x5"

■Size :10"x5"

All Birch 6-ply

BSD0655

BSD1250

BSD1050

### COLOR FINISHES

RB: Raven Black SB: Sapphire Blue CR: Cranberry Red NW: Natural Wood DSM: Dark Silver Metallic

\*BSD1250,1050: Natural Wood (NW) only.

## NSD1365M

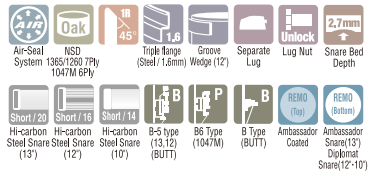

## NSD1260MBGW



## NSD1047M



## Musashi

■Size :13"x6 1/2"

■Size :12"x6"

■Size:10"x4 3/4"

All Oak 7-ply

NSD1365M

NSD1260MBGW

NSD1047M

### COLOR FINISHES

MB : Musashi Black

# YAMAHA CUSTOM SELECT SNARE DRUMS METALLIC SHELL



Detachable Strainer

Nouveau Lug

## ■ Nouveau Lugs on Brass and Copper Shells

Nouveau Lugs utilize a floating design that eliminates contact between the lug casing and shell by hitching the lugs to the bolts at the shell side so the shell can resonate freely. Their quick release design also provides for very quick head changes and reduces the risk of losing washers since it is no longer necessary to entirely remove the tuning bolt.

## ■ Designed to Deliver Greater Power

New Brass and Copper shells (1.5 mm thick) are designed thicker than previous models (1.2 mm thick) to deliver a more powerful tone.

## ■ Brass, Steel Shell Lineup Includes Small Diameter Snares

Brass and steel shells are both available in smaller diameter 13-inch configurations. The steel lineup also includes two 12-inch configurations and a 10-inch model. The 12-inch and 10-inch diameter shells are fitted with rod clamps so you can attach the snare drum to a tom stand and use it as an effect snare.

## ■ “Detachable Strainer” Brass, Copper, and Aluminum Shells

(Detachable Strainers are also employed on the release side of four-inch deep steel models).

## ■ Detachable Snare System (Pat.Pend.)

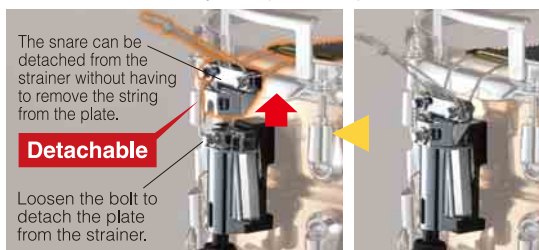

The snare can be detached from the strainer without having to remove the string from the plate.

**Detachable**

Loosen the bolt to detach the plate from the strainer.

Release Side

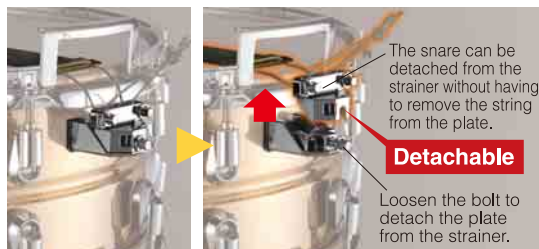

The snare can be detached from the strainer without having to remove the string from the plate.

**Detachable**

Loosen the bolt to detach the plate from the strainer.

Butt Side



## SD2465

### SD2455

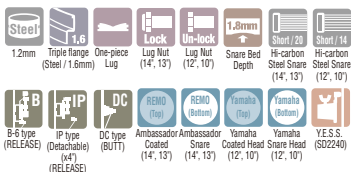

## STEEL

■Size :14"x6 1/2" ■Size :14"x5 1/2" ■Size :13"x5 1/2" ■Size :13"x4" ■Size :12"x5 1/2" ■Size :12"x4" ■Size :10"x5 1/2"

SD2465 SD2455 SD2355 SD2340 SD2255 SD2240 SD2055

## SD266A

### SD265A

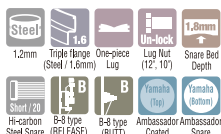

## Stage Custom Steel

■Size :14"x6 1/2" ■Size :14"x5 1/2"

SD266A SD265A

## SD4470

### SD4455

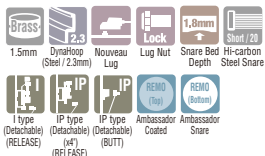

## BRASS

■Size :14"x7" ■Size :14"x5 1/2" ■Size :14"x4" ■Size :13"x6 1/2" ■Size :13"x5 1/2" ■Size :13"x4"

SD4470 SD4455 SD4440 SD4365 SD4355 SD4340

## SD6465

### SD6455

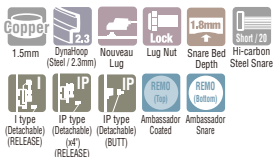

## COPPER

■Size :14"x6 1/2" ■Size :14"x5 1/2" ■Size :14"x4"

SD6465 SD6455 SD6440

## SD3465

### SD3455



## ALUMINUM

■Size :14"x6 1/2" ■Size :14"x5 1/2"

SD3465 SD3455

# Yamaha Drummers (International)



**Tommy Aldridge**  
Whitesnake



**Mike Bordin**  
Ozzy Osbourne



**Paul Bostaph**  
TESTAMENT



**Terri Lyne Carrington**  
Herbie Hancock



**Will Champion**  
Coldplay



**Mino Cinelu**  
Miles Davis, Sting, David Sanborn



**Phil Ehart**  
Kansas



**Sonny Emory**  
Bruce Hornsby, Beie Midler



**Sully Erna**  
Godsmack



**David Garibaldi**  
Tower of Power



**Steve Hass**  
John Scofield



**Roy Haynes**  
Jazz Legend John Scofield



**Steve Jordan**  
Eric Clapton, John Mayer, Tito, Sony, Rollins, James Taylor



**Mannu Kathe**  
Slings, Peter Gabriel, Jan Garbarek



**Shannon Larkin**  
Godsmack



**Russ Miller**  
Independent, LA Studio



**Larry Mullen, Jr.**  
U2



**Xavier Muriel**  
Buckcherry



**Dave Weckl**  
Dave Weckl Band, Chick Corea



**Jon Wyosocki**  
Stand

**Keith Carlock**  
Steely Dan



**Charley Drayton**  
Flona Apple, Michelle Branch



**Steve Gadd**  
Paul Simon, Eric Clapton, James Taylor



**Akira Jimbo**  
Hisa Jimbo, Intelligent Jazz, Independent



**Derrick McKenzie**  
Jamiroquai



**Adam Topol**  
Jack Johnson



**Kozo Suganuma**  
Fragile



**Gorden Campbell**  
Independent



**Caroline Corr**  
The Corrs



**Al Foster**  
McCoy Tyner, Miles Davis



**Tommy Igoe**  
Independent, Gililand Big Band



**Rick Marotta**  
Independent



**Antonio Sanchez**  
Pat Metheny



**Hiroyuki Noriaki**  
Independent



**Matt Cameron**  
Pearl Jam, Sound Garden



**Billy Cobham**  
Independent



**Justin Foley**  
Kilswitch Engage



**Chris Hesse**  
Hoopastank



**Dave MacClain**  
Machine Head



**Questlove**  
The Roots



**Zak Bond**  
Independent



■ Japan

# Yamaha Drummers in Asia, Oceania, Latin

## Argentina



**Charly Alberti**  
Soda Stereo - Mole



**Leonardo Alvarez**  
Seccion



**Leo De Cecco**  
Ataque 77

## Australia



**Mark Charters**  
TSMR, Presence, Theatre



**Toby Dundas**  
The Temper Trap



**Kristian Hopes**  
Grinspoon



**Gordon Fyfe**  
Australian Idol/ Independent



**Shaun Sibbes**  
Sneaky Sound Systems



**KOSTA THEODOSIS**  
Amy Meredith

## Brazil



**Marcel Cardoso**  
Bilancourt Project, Edu Adalmy (Dr. Son), Kiko Loureiro (Angra), Kemna



**Douglas Las Casas**  
Três de Paix, SOLO, Player Session



**Lucas Kastup**  
Ponto de Equilíbrio

## Chile



**Igor Willcox**  
e-COX, SOLO, Player Session



**Carlos Figueroa Salazar**  
Independent-session drummer



**Denny Aid**  
Opera

## Indonesia



**Mochamad Adry Perkasa**  
Nidji



**Wahyu Ptaji**  
Dimasif



**Widi Puradiredia**  
Malik d'sentral



**Triki Handayani/Syuman**  
Independent



**Timotius**  
Saint Loco



**Magi Trisandi**  
Rif



# America, and Eurasian Countries



**Cristian Judurcha**  
Juan Carlos Baglietto



**Daniel Piazzolla**  
Escaladrum



**Leandro Savelon**  
El Cuartito



**Lee Maloney**  
Diesel, Ghostwriters



**Anthony Mitolo**  
Empire of the Sun



**Kimberley Moyes**  
The Presets



**Warren Trout**  
Jimmy Barnes



**Shane Wakker**  
Bodyjar, Cola Wars



**ADAM WESTON**  
Birds Of Tokyo



**Claudio Oliveira**  
Player Session



**Kuki Stolarski**  
Zeca Baleiro, Funk Como Le Gusta



**João Viana**  
Moska, Lella Pinheiro, Jorge Vercillo



**Avin Eka Putra**  
NOXX, Cemetery, Dance Club



**Buddy/Haryono**  
Tiket



**Yadi Mulyadi (Wok)**  
Mata



**Dedy Rhyono**  
Letho



**Roman**  
Urugu



**Raden Adisty Sofie**  
She

## Iran



**Jonas Wang**  
Bl.P, Agnes Monica, OneWay



**Hentresia Vulmedia**  
Independent



**Farzad Gheysarpour**  
Independent

# Yamaha Drummers in Asia, Oceania, Latin

## Iran



**Nima Navapour**  
Independent

## Korea



**Ben Ball**  
Independent



**Lee Sangmin**  
Independent

## Malaysia



**John Ashley Thomas**  
Independent



**Azlan Rudy**  
POP Shuvit



**Jerry Felix**  
Independent



**Bruno Bressa**  
Volovan



**Eduardo Carrillo**  
Agora



**Gilberto "Nut" Castillo**  
Kalimba



**Luis Mario Garza**  
Pessdo



**Enrique "Bugs" Gonzalez**  
Alekis Syntek



**Frankie Mares**  
Trekler



**Jorge "Kross" Vazquez**  
Panda



**Rodrigo Vleyra**  
Ditto



**Servando Yañez**  
Playa Limbo

## Singapore



**Alexander "Poruchik" Schigolev**  
Korol' Shut



**Vladimir Zhurkin**  
Lundstrom's State Jazz Music Chamber Orchestra



**Er Chow Kiat**  
Independent

## Taiwan



**Rafael Lee**  
D.O.M.S.



**Jim Wei**  
Soda Gree



**Andrey Kuzmenchuk**  
Independent

## Ukraine



# America, and Eurasian Countries

## Lebanon



**Sonstar**  
Cherry Filler



**Namgoong Yon**  
Independent



**Waid T. Tawil**  
Independent

## Mexico



**Alfonso Andre**  
Jagueros/Catalanes



**Germán Arroyo**  
La Gusana Ciega



**Gabriel de León "Bonz"**  
Hello Seahorse



**Eliohim Corona**  
Moderatto



**Mario Garcia**  
Big Band Mexico



**Rodrigo Guardiola**  
Zoe



**Julio Moran**  
Independent



**Rodrigo Ortega**  
Carnilla



**Daniel Terrazas**  
Montez de Durango

## Russia



**Oleg Butman**  
Oleg Butman's Trio



**Grigory "GREG" Karpov**  
SDIZ



**Dmitry Krivenkov**  
Epidemia

## Thailand



**Robert Nalin**  
Independent



**Aekpong Cherdtham**  
Crescendo



**Sutipong Pankong**  
Infinity

## Venezuela



**Miguel Hernandez**  
Independent



**Adolfo Herrera**  
Wahala

## Yamaha Signature Snare Drums

andre **CECCARELLI****Andre Ceccarelli Signature Model**■ **MSD1455AC**

Maple shell, 14" x 5 1/2",  
4-ply with Reinforcement, 10-lugs,  
Zinc die-cast hoop, Special chrome,  
Lime Green Sparkle finish

jimmy **CHAMBERLIN****Jimmy Chamberlin Signature Model**■ **SD2455JC**

Steel shell, 14 x 5 1/2",  
10-lug, aluminum die-cast hoops;  
Matte Chrome finish

ndugu **CHANCLER****Ndugu Chancler Signature Model**■ **SD255ANC**

Steel shell, 14" x 5 1/2",  
10-lug, 2.3mm DynaHoop,  
snare diverter, White finish

billy **COBHAM****Billy Cobham Signature Model**■ **ASD1460BC**

Maple shell, 14" x 6", 6-ply, 8-lug,  
19-ply vintage wood hoop, extended  
snare; Silver Sparkle or Solid Black finish

sonny **EMORY****Sonny Emory Signature Model**■ **WSD1455SE**

Beech shell, 14" x 5 1/2",  
8-ply/10mm shell, 10-lug,  
zinc die-cast hoop, special grain,  
Vintage finish



anton **FIG****Anton Fig Signature Model**■ **MSD14AF**

Maple shell, 14" x 6", 7-ply, 10-lug, 19-ply vintage wood hoop, vintage interior finish, Solid Black finish

steve **GADD****Steve Gadd Signature Model**■ **BSD14ASG**

Birch shell, 14" x 5", 6-ply, 10-lug, black vintage wood hoops, decagonal-shape bottom hoop, 3.5mm snare bed, Solid Black finish

■ **MSD14ASG**

Maple shell, 14" x 5", 7-ply, 10-lug, black vintage wood hoops, decagonal-shape bottom hoop, 3.5mm snare bed, Solid Black finish

■ **SD255ASG**

Steel shell, 14" x 5 1/2", 10-lug, black vintage wood hoops, decagonal-shape bottom hoop, 3.5mm snare bed, Black finish

david **GARIBALDI****David Garibaldi Signature Model**■ **SD435ADG**

Brass shell, 14" x 3 1/2", 10-lug, zinc die-cast rims, Blue Nickel Alloy finish

roy **HAYNES****Roy Haynes Signature Model**■ **SD655ARH**

Hand-hammered copper shell, 14" x 5 1/2", 10-lug, 2.3mm steel triple-flange rims, internal muffler



## Yamaha Signature Snare Drums

akira **JIMBO****Akira Jimbo Signature Model**■ **WSD13AJ**

Beech shell, 13" x 7", 8-ply, 6-lug, Vintage interior finish, White Sparkle finish

*Akira Jimbo*

kozo **SUGANUMA****Kozo Suganuma Signature Model**■ **SD6455KS**

Copper Shell, 14" x 5 1/2", 10 lug, zinc die-cast hoops, No Center Beads on Shell

*Kozo Suganuma*

elvin **JONES****Elvin Jones Signature Model**■ **MSD1470EJ**

Maple shell, 14" x 7", 7-ply, 10-lug, 19-ply vintage hoop, gold lug, Gold Sparkle finish

*Elvin Jones*

dave **WECKL****Dave Weckl Signature Model**■ **MSD14ADW**

Maple shell, 14" x 5 1/2", 8-lug, Nouveau lug casings, aluminum die-cast hoops, dual strainer design, Solid Black finish

■ **MSD13ADW**

Maple shell, 13" x 5 1/2", 6-lug, Nouveau lug casings, aluminum die-cast hoops, dual strainer design, Solid Black finish

*Dave Weckl*



manu **KATCHÉ****Manu Katché Signature Model**■ **SD465AMK**

Black-plated brass shell, 14" x 6 1/2",  
10-lug, zinc die-cast top hoop/aluminum  
die-cast bottom hoop,  
Black Nickel Alloy finish

■ **SD455AMK**

Black-plated brass shell, 14" x 5 1/2",  
10-lug, zinc die-cast top hoop/aluminum  
die-cast bottom hoop,  
Black Nickel Alloy finish



MANU KATCHÉ

paul **LEIM****Paul Leim Signature Model**■ **SD465APL**

Chrome-plated brass shell, 14" x 6 1/2",  
black-chromed aluminum die-cast hoops,  
dual strainer, one-piece gold-plated lugs,  
30-strand snares

■ **SD455APL**

Chrome-plated brass shell, 14" x 5 1/2",  
black-chromed aluminum die-cast  
hoops, dual strainer, one-piece gold-  
plated lugs, 30-strand snares



Paul Leim

mike **BORDIN****Mike Bordin Signature Model**■ **SD6465MB**

Copper shell, 14 x 6 1/2", 10-lug,  
2.3mm black-finished DynaHoop,  
hand-hammered bottom half  
shell; Clear Black finish



Mike Bordin

steve **JORDAN****Steve Jordan Signature Model**■ **MSD1365SJ**

Maple shell, 13" x 6 1/2", 4-ply with  
reinforcement rings, 8-lug,  
1.6mm triple-flanged hoop,  
Matte Natural finish

■ **SD08CJ**

Birch/mahogany shell, 8" x 5", 7-ply,  
5 lugs, YESS mounting bracket, L-arm  
mounts directly to cocktail drum,  
Silver Sparkle or Pink Sparkle finish



Steve Jordan

# YAMAHA SYSTEM HARDWARE

Hardware should maximize the performance and capabilities of the drum. Drummers worldwide have long held Yamaha hardware in high regard for its outstanding durability and reliability.

New products like our pattern-less footboards were each conceived from ideas brought to us by individual players. As times, music, players, and possibilities evolve, so does Yamaha System Hardware.

## In Pursuit of Smooth Action

(FP9500D Series)

The FP9500D's light pedal work is made possible through the utilization of an aluminum die-cast link. The pedal stroke starts out light when pressed but delivers dynamic pedal action with an overwhelming sense of speed. (FP9500D, DFP9500D)

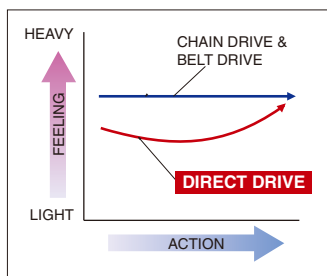

## New Footboard Design

The wider pedal design provides a larger contact surface for your foot delivering a lighter feel and greater playability. Grip is enhanced in the heel section, and the pattern-less surface offers both moderate gripping and smooth movement. A weight balance on the end delivers great playability. (FP9500 series, DFP8500 series, DFP series)

The FP8500C/8500B both feature longer footboards. The same length as used on the hi-hat pedals offers smoother switching to the sub pedal.





**Foot Pedal**  
**Hihat Stand**  
**Cymbal Stand**  
**Snare Stand**  
**Drum Stool**  
**Tom Holder**  
**Double Tom Stand**



## 4 Drive System Types

Four Drive Types Offer Four Different Feels



### Direct Drive

9500D

A die-cast aluminum link provides a direct connection between the pedal and beater that transmits pedal control directly to the beater. This high performance drive delivers an overwhelming sense of speed. (FP9500D, DFP9500D)



### Double Chain Drive

9500C, 8500C

The double chain drive offers reliable and durable operation with uniform action. The FP9500C/8500C and DFP9500C/9500CL come with a belt letting you switch to a belt drive system if preferred.



### Single Chain Drive

7210A

The single chain drive provides uniform action with a natural feel.



### Belt Drive

8500B

The belt drive has supple touch and feel that isn't found in chain drive systems.

# Foot Pedal



## 2-Way Beater

This convertible beater incorporates two types of beaters into a single unit. One side is a normal felt type while the other is made of plastic that delivers a feeling close to wood. (FP9500, DFP9500 series)



## Beater Angle Adjustment

Loosening the adjustment screw lets you freely adjust the beater angle along with the footboard angle. (All models)



## Beater Shaft Rocker (Pat. Pend.)

The teardrop shaped shaft hole holds the shaft securely. (All models)  
The shaft's flat surface keeps the 2-way beater from swiveling while playing.

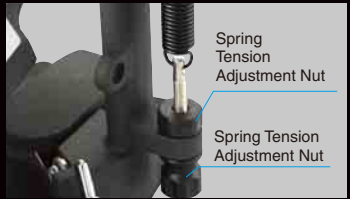

## Spring Tension Adjustment Lock System

One hand spring tension adjustment is easy. A lock bolt secures the setting to prevent loosening during play. (Excluding FP7210A)



## Spring Roller with Built-in Bearings

Precision bearings deliver smooth, natural pedal action. (Excluding FP7210A)



## Base Frame Tie Rods

Rubber coated tie rod ends prevent the footboard and base frame from becoming disconnected. (FP8500B)



## Footboard Angle Adjustment

The pedal angle can be set freely to any angle without affecting beater angle. This lets you set the pedal angle you want when the pedal is not pressed. A tuning key is used to make the adjustment, which also lets you align pedal height with your sub, and hi-hat pedals. (FP/DFP9500 Series)



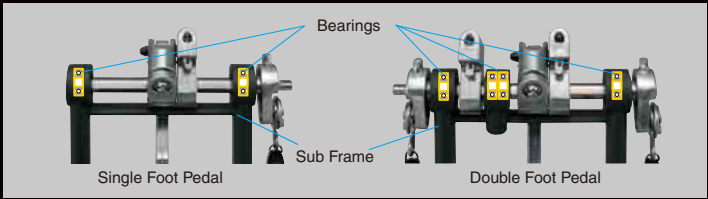

## Frame Structure

This Yamaha original design incorporates a sub-frame just below the rocker shaft to deliver greater stability and durability. Drummers will experience smoother, more stable movement particularly in double pedal setups since bearings for both the main and remote beaters are incorporated into the sub-frame. (All models)

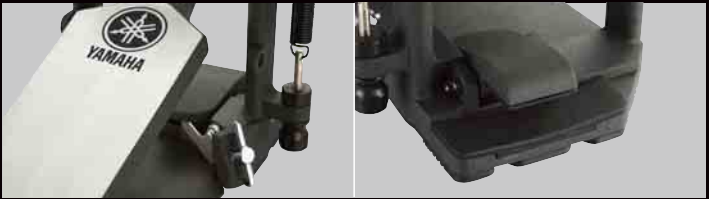

## Bass Drum Hoop Clamp

A wing bolt firmly tightens the clamp for secure attachment. It also allows the clamp to accommodate different hoop thicknesses.



## Smooth Moving Universal Joint

A universal joint on the rocker shaft provides angular flexibility for smoother movement. (All models with double foot pedals).



## Compact and Convenient Semi-Hard Case

The 9500 Series pedals come with a specially designed semi hard case. This case provides protection from damage even when storing the pedals in the trunk case along with the stands that are missing their rubber feet. (FP9500 series, DFP9500 series)



# Foot Pedal

Single Foot Pedal  
**FP9500C**



Double Foot Pedal  
**DFP9500C**



Single Foot Pedal  
**FP9500D**



Double Foot Pedal  
**DFP9500CL**



Double Foot Pedal  
**DFP9500D**



## Specification List

	Direct Drive		Do	
	FP9500D	DFP9500D	FP9500C <small>(Convertible to the</small>	DFP9500C
Yamaha Base Plate	●	●		●
Semi-Hard Case	●	●		●
Yamaha's Frame Design	●	●		●
BD Hoop Clamp System	●	●		●
Foot Board Angle Adjustment	●	●		●
Patternless Foot Board	●	●		●
Tear Drop Beater Shaft Rocker	●	●		●
Beater Angle Adjustment	●	●		●
Spring Roller with Bearings	●	●		●
Spring Adjust Lock System	●	●		●
Long Foot Board	—	—		—
2way Beater	●	●		●

Single Foot Pedal  
**FP8500C**



Double Foot Pedal  
**DFP8500C**



Single Foot Pedal  
**FP8500B**



Single Foot Pedal  
**FP7210A**



## Option

Felt Beater  
**BT610A**



Felt Beater  
**BT810A**



Felt Beater  
**BT910A**



Felt Beater  
**BT912A**



Wood Beater  
**BT914A**



2-Way Beater  
**BT950**



	Belt Chain Drive		Belt Drive	Single Chain Drive
<b>Belt Drive)</b> <b>DFP9500CL</b> (L Type)	<b>FP8500C</b>	<b>DFP8500C</b>	<b>FP8500B</b>	<b>FP7210A</b>
		●	(Linked with connecting rods)	(Linked with connecting rods)
	—	—	—	—
	●	●	●	●
	●	●	●	—
	—	●	●	—
	●	●	●	—
	●	●	●	●
	●	●	●	●
	●	●	●	—
	●	●	●	—
	—	—	—	—

# Hi-Hat Stand



## Cymbal Holder and Angle Adjustment

The reversible design features felt on one side and rubber on the other, and can be switched according to your needs.

Also, a newly designed angle adjustment screw automatically locks after adjustment to prevent loosening during performance.

(HS1200T, 1200D, 1200)



## Drum Key Holder

Keep your drum key in the handy holder on the stand's pipe.

(HS1200T, 1200D, 1200)



## Single and Double Braced Legs

A double-braced center leg and single-braced side legs provide stability while reducing interference with adjacent stands in your setup.

(HS1200)



## Spring Tension Adjustment

Spring tension adjustment (the force that opens the top cymbal) is quick with the large dial. The new design makes it easy to rotate and an indicator located under the dial gives you a visual indication of the amount of tension set.

(HS1200T, 1200D, 1200)

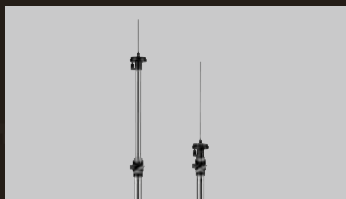

## Long and Regular Rods

Hi-hat cymbal height

With long rod: 739.5mm-1052mm

With Regular rod: 739.5mm-902mm

Two rods, one long one supplied to accommodate lower plating positions.



## Footboard

The new wider pedal design provides a greater contact surface for your foot delivering a lighter feel and greater playability. Grip is enhanced in the heel section, and the patternless surface provides both moderate gripping and smooth movement. A weight balance on the end delivers great playability. Slim form allows closer setting of the double foot pedal.

(HS1200T, 1200D, 1200)



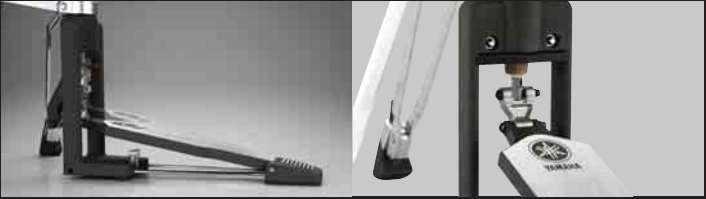

## Footboard Angle Adjustment

Pedal angle, when not depressed, can be set freely. This lets you align pedal height with other pedals such as in a double foot pedal setup. Rubber coated tie rods help to prevent pedal hopping. (HS1200T, 1200D, 1200)

## Big Rubber Feet and Spikes

A push-lock spike incorporated into the large rubber feet offer additional stopping power. Extending and retracting the spikes are as easy as pressing the push lock. (HS1200T, 1200D, 1200)

## Toggle Link System

The toggle link system on the HS1200T offers light and nimble pedal work. The first part of the pedal stroke feels really light but becomes increasingly heavier and closer to normal weight as the pedal stroke progresses. There is also little impact on the frame when the foot is removed from the pedal and the system delivers quiet operation. (HS1200T)

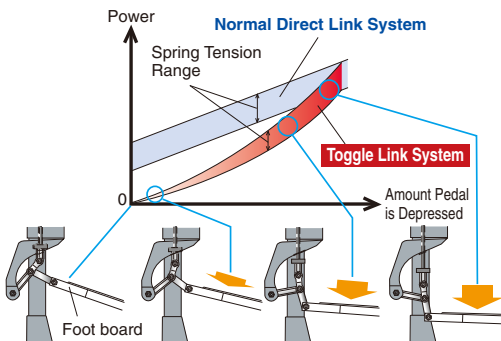

(1) Compared to normal direct link systems, the feeling is very light at the top of the stroke. And even if spring tension is increased, the amount of power required at the top of the stroke does not change.

(2) As the pedal is further depressed, it starts to react more like a normal direct link system with the end of the stroke feeling nearly the same as a normal direct link pedal. The peculiar action produced by this power enhancing system (lever, etc.) decreases as the pedal is depressed.

# Hi-Hat Stand

Hi-Hat Stand  
**HS1200T**



Hi-Hat Stand  
**HS1200D**



Hi-Hat Stand  
**HS1200**



## Option

Long & Regular Rods  
**PERS**



Extension Rod  
**PERL**

This extension rod adds an extra 4" (10cm) of height to the hi-hat stand.



Model No.	<b>HS1200T</b>	<b>HS1200D</b>	
Available Height Range	74 ~ 105cm	74 ~ 105cm	
Locking Hi-hat Clutch	●	●	
Cymbal Support	Hard Rubber / Felt	Hard Rubber / Felt	
Cymbal Angle Adjustment	● (w/Fixing Nut)	● (w/Fixing Nut)	
Rotating Leg Design	●	●	
Spring Tension Adjustment	● (with Indicator)	● (with Indicator)	
Foot Board Angle Adjustment	●	●	
Toggle Link System	●	—	
Big Rubber Feet	● (with Spike)	● (with Spike)	
Leg Design	2 Double Braced Legs	2 Double Braced Legs	
Length of included Rod	Long & Regular Rod	Long & Regular Rod	

Hi-Hat Stand  
**HS850**



Hi-Hat Stand  
**HS740A**



Hi-Hat Stand  
**HS650A**



Locking Hi-hat Clutch  
**LC930A**



Hi-hat Clutch  
**LC810A**



Closed Hi-hat Holder  
**CHH930**

Position a hi-hat in your setup anywhere you like. Spring tension is adjustable.



<b>HS1200</b>	<b>HS850</b>	<b>HS740A</b>	<b>HS650A</b>
74 ~ 105cm	70 ~ 92cm	70 ~ 90cm	65 ~ 90cm
●	—	—	—
Hard Rubber	Felt	Felt	Felt
● (w/Fixing Nut)	●	●	●
●	●	●	—
● (with Indicator)	●	● (11 Increments)	—
●	—	—	—
—	—	—	—
● (with Spike)	●	●	(Normal)
3 Double/Single Braced Legs (Front side legs angle open 150 degree)	3 Double Braced Legs (Front side legs angle open 150 degree)	3 Single Braced Legs (Front side legs angle open 150 degree)	3 Single Braced Legs (Front side legs angle open 120 degree)
Long & Regular Rod	Regular Rod	Regular Rod	Regular Rod

# Snare Stand

Snare Stand  
**SS950**



Snare Stand  
**SS850**



Snare Stand  
**SS740A**



Snare Stand (for 12")  
**SS662**



Model No.	<b>SS950</b>	<b>SS850</b>
Available Height Range	45 ~ 61cm	45 ~ 63cm
Rubber Arms	3 Arms	3 Arms
Adjustable Angle Tilter	●	—
Big Rubber Feet	● (With Spike)	●
Leg Design	3 Double Braced Legs	3 Double Braced Legs

# Cymbal Stand

Boom Cymbal Stand  
**CS965**



Boom Cymbal Stand  
**CS755**



Boom Cymbal Stand  
**CS665A**

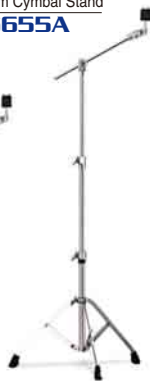

Boom Cymbal Stand  
**CS865**

Boom Cymbal Stand  
**CS665A**

Model No.	<b>CS965</b>	<b>CS865</b>	<b>CS755</b>	<b>CS665A</b>
Available Height Range	91 ~ 172cm	94 ~ 175cm	91 ~ 172cm	80 ~ 163cm
Offset Tilter	—	—	—	●
Center Tilter	—	—	●	—
New Step Free Tilter	●	●	—	—
Big Rubber Feet	●	●	●	—
Leg Design	3 Double Braced Legs	3 Double Braced Legs	3 Single Braced Legs	3 Double Braced Legs



### Adjustable Angle Tilter

Snare angle adjustment is speedy and flexible. Yamaha's exclusive Ball Clamp design on the SS950 lets you set your snare at any angle you like. The large wing bolt tightens securely to hold the angle.



### Snare Basket

Adjustment Knob  
Improved grip design delivers great gripping power.



### Big Rubber Feet and Spikes

In addition to the wide leg stance, the big rubber feet deliver maximum grip to hold the stand securely in place.

	<b>SS740A</b>	<b>SS662</b>
	45 ~ 61cm	43 ~ 62cm
	3 Arms	3 Arms (for 12" Snare Drum)
	—	—
	●	—
	3 Single Braced Legs	3 Single Braced Legs

Straight Cymbal Stand  
**CS850**

Straight Cymbal Stand  
**CS750**

Straight Cymbal Stand  
**CS660A**

Straight Cymbal Stand  
**CS650A**



	<b>CS655A</b>	<b>CS850</b>	<b>CS750</b>	<b>CS660A</b>	<b>CS650A</b>
	79 ~ 162cm	73 ~ 154cm	73 ~ 154cm	63 ~ 146cm	62 ~ 145cm
	●	—	—	●	●
	—	—	●	—	—
	—	●	—	—	—
	—	●	●	—	—
gs	3 Single Braced Legs	3 Double Braced Legs	3 Single Braced Legs	3 Double Braced Legs	3 Single Braced Legs

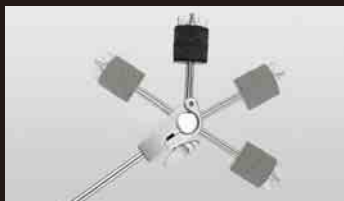

### New Step Free Tilter

Step free angle adjustment lets you set the cymbal at any position you like. Supporting the cymbal's weight in the center of the pipe provides a more stable setting. (CS900 Series, CS800 Series)



### Center Tilter

The Center Tilter, long popular among knowledgeable players, has been revived in the CS700/CH700 Series, CSAT942/940 and CWH940 series. By supporting the weight of the cymbal at the center, greater stability is achieved.



### Offset Tilter

The offset tilter stores parallel to the pipe making transport easy and preventing damage. This tilter is used in the CS600 series, which is noted for its light, compact design.



### Placing Type Boom Tilter Mechanism

Retaining YAMAHA's traditional gear mechanism, we now introduce the "clipping" method for securing the boom arm. Through this specification, the main unit of the boom arm becomes more resistant to scratches. It ensures extra peace of mind, even during complex setup adjustments. It begins with the CS965, 865, 755, CH755, 750.

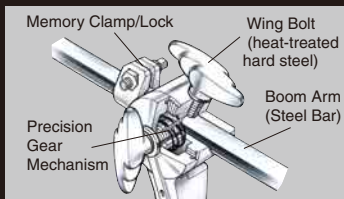

### Pressing type Boom Tilter Mechanism

A precision gear mechanism provides precise adjustment of the boom arm's angle. A wing bolt firmly fixes the boom arm in place while a memory clamp/lock offers quick positioning and prevents rotating. (CS665A, 655A)

### Small Wing Nut, Tilter Sleeve & Felt

A polycarbonate tilter sleeve encases just enough of the head bolt to provide optimum securing of the cymbal. Utilization of a wing nut lets you play the cymbal bell without it getting in the way of the stick.

### Boom Cymbal Holder

Yamaha's cymbal holder fits into the main pipe making it easier to pack and transport.

### Tight & Secure

Specially designed by Yamaha, the nylon bushing holds the pipe firmly in place even when lightly tightened. Since the wing bolt is tightened through a steel nut, the durability of the bolt is increased. (All models)

### Unified Diameter Center Pipe

The center tube assembly accommodates the same 22.2mm diameter pipe as found on other stands so you can replace the upper tube assembly with that of another cymbal stand or tom holder. (except CS655A, CS650A)

### Big Rubber Feet

In addition to wide stance legs, the big rubber feet supply maximum non-slip grip to keep the stand firmly in place.



# Option

## Cymbal Stand Boom Weight

### **CSBW**



Cymbal Holder  
**CH750**



Cymbal Holder  
**CH755**



Cowbell Holder  
**CWH940**

## Cymbal Stand Attachment

### **CSAT940**

The CSAT940 can be used for two stage cymbal arrangements or a closed hi-hat arrangement.

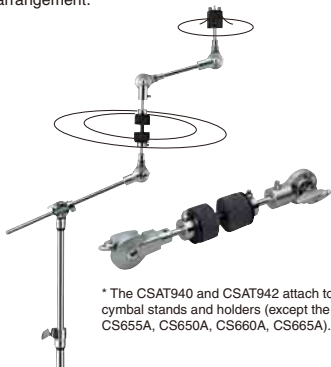

\* The CSAT940 and CSAT942 attach to cymbal stands and holders (except the CS655A, CS650A, CS660A, CS665A).

## Cymbal Stand Attachment

### **CSAT924A**

The CSAT924A connects to the pipes of stands and holders allowing a wide variety of set-ups and positions to be easily achieved.



## Cymbal Stand Attachment

### **CSAT942**

The CSAT942 connects to the tilter and offers fine angle adjustment.



# Tom Holder



## Ball Mount & Clamp

The Yamaha original ball mount and clamp system offers unparalleled flexibility and ease of positioning. A generous sized hard synthetic resin ball sits in an attractive chromed housing that permits the tom hex rod to be positioned in almost any imaginable position. The ball joint friction-free operation provides ease of set up, while a large wing bolt provides one touch locking.

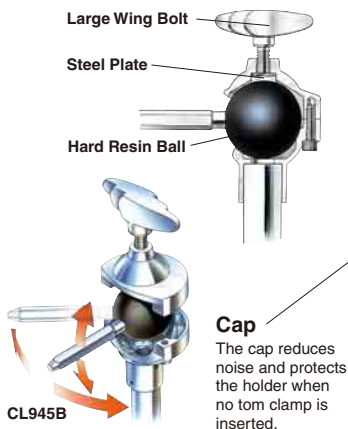

Tom Clamp(for YESS)  
**CL945LB**



Tom Clamp(for YESS)  
**CL945B**



Tom Clamp  
**CL940LB**



Tom Clamp  
**CL940B**



		Tom H
Model No.	<b>TH945B</b>	
Rod	Short (for YESS)	
Tom Holder Base	Triple Mount	
		Tom C
Model No.	<b>CL945LB</b>	<b>CL945B</b>
Rod	Short (for YESS)	Short (for YESS)
Pipe	Long	Short

### Memory Clamp

Attaching the clamp at an ideal position reduces setup time. Helps eliminate rattle and noise and can be used inverted.

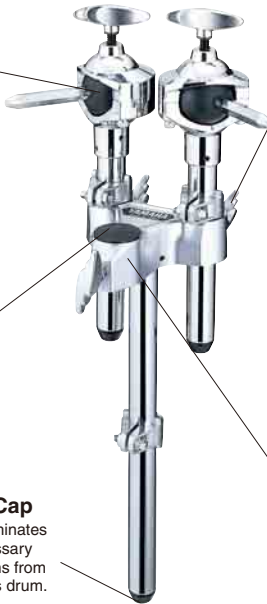

### Pipe Cap

Cap eliminates unnecessary vibrations from the bass drum.

### Triple Tom Holder

The Yamaha triangular triple tom holder expands the range of possibilities for creative setups. Cymbals or tom toms can be added as your style demands.

Tom Holder(for YESS)  
**TH945B**



Tom Holder  
**TH940B**



Tom Holder  
**TH904A**

The TH904A fits into a cymbal stand's lower pipe section. (Except the CS650A and CS655A)



### Holder

	<b>TH940B</b>
	Long
	Triple Mount

### Clamp

	<b>CL940LB</b>	<b>CL940B</b>
	Long	Long
	Long	Short

# Double Tom Stand

## Double Tom Stand

Yamaha's double tom stands have long been recognized for their outstanding freedom in positioning drums. Their simple and durable design offers stable setting while the ball clamp system's ability to rotate 360 lets you position your toms or an additional snare drum exactly where you want.

Double Tom Stand  
(for YESS)  
**WS955A**

Double Tom Stand  
**WS950A**

Double Tom Stand  
(for YESS)  
**WS865A**

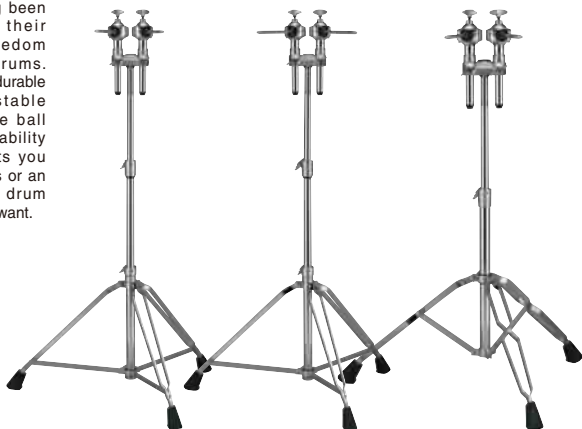

Model No.	<b>WS955A</b>	<b>WS950A</b>
Available Height Range	58 ~ 130cm	58 ~ 130cm
Rod	Short (for YESS)	Long
Tom Holder Base	Triple Mount	Triple Mount
Big Rubber Feet	●	●
Leg Design	3 Double Braced Legs	3 Double Braced Legs

# Stool

## Large Seat Mount

(480mm x 390mm)



Model No.	<b>DS950</b>	<b>DS840</b>
Seat	Large Square Seat Design 480(W)x390(D)mm	Round Seat Design 330mm(Diameter)
Seat Mount	Large AL Die-cast Seat Mount	Large AL Die-cast Seat Mount
Height Adjustment	Screw Rod (460 ~ 650mm)	Screw Rod (460 ~ 650mm)
Leg Ass'y	4 Double Braced Wide Stance Legs	3 Double Braced Wide Stance Legs

Double Tom Stand  
**WS860A**



Double Tom Stand  
(for large diameter tom 14", 15", 16")

**WS904A**

Light in weight, this stand's excellent stability can easily hold a pair of large toms.



Like the tom holder, all double tom stands utilize the triple hole base.

<b>WS865A</b>	<b>WS860A</b>	<b>WS904A</b>
62 ~ 104cm	62 ~ 104cm	45 ~ 76cm
Short (for YESS)	Long	—
Triple Mount	Triple Mount	Triple Mount
●	●	●
3 Double Braced Legs	3 Double Braced Legs	3 Double Braced Legs

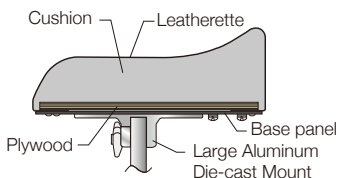

**Large Seat Mount**

Aluminum die-cast type. Offers great stability and durability. (DS950, 840)



**Large Seat Mount**

Rotate the seat to adjust height then tighten the clamp to secure. (DS950, 840)



**Back Support**  
**BK5110**  
(for DS950)

<b>DS750</b>	<b>DS550U</b>
Round Seat Design 300mm(Diameter)	Round Seat Design 300mm(Diameter)
AL Die-cast Seat Mount	AL Die-cast Seat Mount
Clamp Rod Type (430 ~ 650mm)	Clamp Rod Type (420 ~ 600mm)(no hole, w/memory clamp)
3 Single Braced Legs	3 Single Braced Legs

# Wood Hoops



Size : 16"    Size : 14"    Size : 13"



Size : 12"    Size : 10"    Size : 8"

Model	Application	Diameter	Holes
VH0805T	Tom Tom	8"	5
VH1006T	Tom Tom	10"	6
VH1206T	Tom Tom	12"	6
VH1306T	Tom Tom	13"	6
VH1408T	Tom Tom	14"	8
VH1408F	Floor Tom	14"	8
VH1508T	Tom Tom	15"	8
VH1608T	Tom Tom	16"	8
VH1608F	Floor Tom	16"	8
VH1808F	Floor Tom	18"	8
VH1408S	Snare	14"	8
VH1410S	Snare	14"	10

# Snares

## HI-CARBON STEEL SNARES

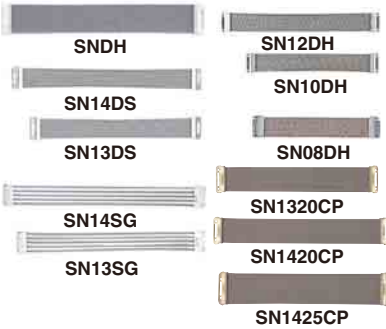

## STAINLESS STEEL SNARES

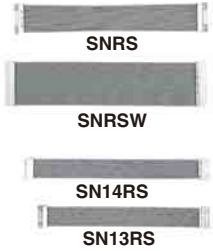

	Model	Strands	Application
Hi-carbon Steel	SN-DH	20 strands	Short
	SN-14DS	14 strands	Short
	SN-13DS	14 strands	Short
	SN-14SG	10 strands	Short
	SN-13SG	10 strands	Short
	SN-12DH	14 strands	Short
	SN-10DH	14 strands	Short
	SN-08DH	14 strands	Short
	SN-DL	20 strands	Long
	SN-D	20 strands	Short
	SN-1314	14 strands	Short
	SN-1425	25 strands	Short
	SN-1525	25 strands	Short
	SN-1320CP	20 strands	Coated Finish/Short
SN-1420CP	20 strands	Coated Finish/Short	
SN-1425CP	25 strands	Coated Finish/Short	
Stainless Steel	SN-RS	20 strands	Short
	SN-RSW	30 strands	Short
	SN-14RS	14 strands	Short
	SN-13RS	14 strands	Short
	SN-14SW	14 strands	Short
	SN-14SWL	14 strands	Long
Brass	SN-E	8 strands	Long



## Ring Mutes



- MU13SG**  
13" (Width 18mm) Black
- MU14SG**  
14" (Width 18mm) Black
- MU13S2**  
13" (Width 18mm)
- MU14S2**  
14" (Width 18mm)
- MU14S1**  
14" (Width 36mm)

## Snare Strings & Tapes



- SNC10** (4 Snare Strings)
- SNT10** (4 Snare Tape)

## Staging Heads



- 250BL** Black
- 250BLH**  
Black with Cut Out
- 250BLH2**  
Black with Small Cut Out
- 250SWH2**  
White Smooth with Cut Out

Size	BD18 (18")	BD20 (20")	BD22 (22")	BD24 (24")	BD26 (26")
250BL	SH18250BL	SH20250BL	SH22250BL	SH24250BL	SH26250BL
250BLH	—	SH20250BLH	SH22250BLH	SH24250BLH	SH26250BLH
250BLH2	—	SH20250BLH2	SH22250BLH2	SH24250BLH2	—
250SWH2	*SH18250SW	SH20250SWH2	SH22250SWH2	SH24250SWH2	—

\*SH18250SW has no cut out.

## Tuning Keys



**DK15**

**DK20**

# Rack

## HXR4LD

Size: 2,100(W) x 1,100(D) x 920(H) mm  
(83 x 44 x 37 inch)

▶ DTX 950K



## RS130

Size: 1,600(W) x 1,000(D) x 980(H) mm  
(63 x 40 x 39 inch)

▶ DTX 900K

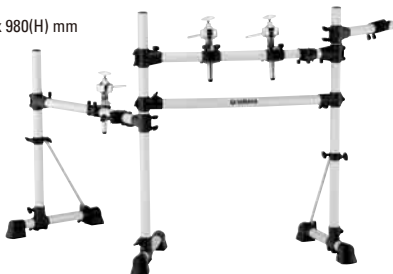

## RS700

Size: 1,346(W) x 766.3(D) x 835(H) mm  
(53 x 30 x 33 inch)

▶ DTX 750K



## RS500

Size: 1,196(W) x 528.3(D) x 812.3(H) mm  
(47 x 21 x 32 inch)

▶ DTX 700K / 540K / 520K



## RS85A

Size: 840(W) x 670(D) x 980(H) mm  
(33 x 26 x 39 inch)

▶ DTX 550K



## RS40

Size: 740(W) x 570(D) x 980(H) mm  
(30 x 23 x 39 inch)

▶ DTX 500K



## Package List

Kit	DTX950K	DTX900K	DTX750K
Tone Generator	DTP900		DTP700
Pad Set 1	DTP902	DTP901	DTP750P
	XP120SD, XP100Tx2, XP120Tx2, HS740A, CH755	XP120SD, XP100Tx3, HS740A, CH755	XP100SD, XP80x3, KP65, SS662
Pat Set 2	DTP900		DTP750C
	KP125W, PCY135x2, PCY155, RHH135, CH750x2, SS662		PCY135x2, PCY155, RHH135, HS650A, CH750x2, CHH755
Rack	HXR4LD	RS130	RS700

# Monitor System

Designed for mounting on the DTXdrums tube racks, these monitor systems incorporate a pair of satellite speakers matched with a powered sub-woofer. The punchy bass and stereo sound projects toward you from the kit so you'll feel like you are playing acoustic drums.

## MS100DR Includes Speaker Cable x2, Phone Cable x2



**40W Satellite Speakers**  
Size: 127(W) x 106(D) x 205(H) mm  
(5 x 4-11/16 x 8-5/64 inch)



**SPAT1 Speaker Attachment**



**100W Sub Woofer Unit**  
Size: 540(W) x 350(D) x 505(H) mm  
(21-17/64 x 13-25/32 x 19-57/64 inch)

## MS50DR Includes Speaker Cable x2, Phone Cable x2



**20W Satellite Speakers**  
Size: 127(W) x 106(D) x 205(H) mm  
(5 x 4-11/16 x 8-5/64 inch)



**SPAT1 Speaker Attachment**



**50W Sub Woofer Unit**  
Size: 451(W) x 330(D) x 380(H) mm  
(17-3/4 x 13 x 15-31/32 inch)

## MS40DR Includes Speaker Cable x2, Phone Cable x2



**20W Satellite Speakers**  
Size: 97(W) x 159(D) x 178(H) mm  
(3-13/16 x 6-1/4 x 7 inch)



**40W Sub Woofer Unit**  
Size: 350(W) x 210(D) x 321(H) mm  
(13-25/32 x 8-17/64 x 12-41/64 inch)



# Option



**Cymbal Attachment (w/Clamp) CYAT150**



**Cymbal Attachment (w/Clamp) CYAT65**

**Tom Holder (w/Clamp) TPCL150**



**Tom Holder (w/Clamp) TPCL65**



**SPAT1 Speaker Attachment**

SPAT1 holds a pair of Yamaha (MSP3, MS101 III) or similar speakers. (L/R side set)

\* Not intended for use with speakers weighing over 5kg.



**Drum Trigger DT10**



**Drum Trigger DT20**

**UX16 USB-MIDI INTERFACE**



This bus-powered USB MIDI interface does not require a power adaptor and offers 16 OUT/16 IN MIDI Channel control.

\* Attaches to the shell or head on an acoustic drum and transmits a trigger signal to the drum trigger module.

DTX700K	DTX540K	DTX520K	DTX550K	DTX500K
<b>DTX500</b>				
<b>DTP700P</b>		<b>DTP520P</b>	<b>DTP502</b>	<b>DTLK9</b>
XP80, XP70x3, KP65		XP80, TP65x3, KP65	TP65x3, PCY135, PCY155, RHH135, HS650A, KP65	TP65x5, KP65, PCY65x2, HH65, FP6110A
<b>DTP700C</b>	<b>DTP520C</b>		<b>XP100SD</b>	/
PCY135x2, RHH135, HS650A	PCY135, PCY100x2, HH65, HH Holder		XP100SD	
<b>RS500</b>			<b>RS85A</b>	<b>RS40</b>

# Snare/Tom

## 3-Zone Pad

A 3-zone design offers the same expressive capabilities as acoustic drums, making closed rim shots, open rim shots, and other playing techniques possible.

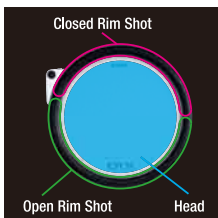

## Pad Controller

Pad pitch and snare tension are adjustable from the pad with a single knob. (XP120SD/T, XP100SD/T)



### XP120SD

Size: 12-inch Snare  
▶ DTX 950K / 900K

### 3-Zone Pad



### XP120T

Size: 12-inch Tom  
▶ DTX 950K

### 3-Zone Pad



### XP100SD

Size: 10-inch Snare  
▶ DTX 750K

### 3-Zone Pad



### XP100T

Size: 10-inch Tom  
▶ DTX 950K / 900K

### 3-Zone Pad



### XP80

Size: 8-inch Snare / Tom  
▶ DTX 750K / 700K  
540K / 520K

### 3-Zone Pad



### XP70

Size: 7-inch Snare / Tom  
▶ DTX 700K / 540K

### 1-Zone Pad



### TP65S

Size: 7.5-inch Snare / Tom

### 3-Zone Pad



### TP65

Size: 7.5-inch Snare / Tom  
▶ DTX 520K / 500K

### 1-Zone Pad

# Cymbal/Hi-Hat/Kick

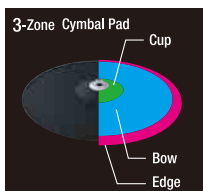

## The Hi-Hat System that Reproduces Your Every Nuance

The RHH135 features a vertical-motion hi-hat system that uses a genuine Yamaha hi-hat stand (as provided with the DTXdrums kit) and produces a realistic feeling pedal action. Moreover, the system can express various hi-hat techniques, such as open/close position, half open, closed pedal and foot splash.

By using a real stand you can match your acoustic setup to make practice more effective.



## Cymbals that Deliver Realistic Expression Performance

The 3-zone cymbal pad, which can express a different sound in each of the cup, bow and edge zones. It also has the "choke" function, providing performance expression similar to that of an actual cymbal.



### PCY155

Size: 15-inch

► DTX 950K / 900K / 750K

**3-Zone Pad**



### PCY135

Size: 13-inch

► DTX 950K / 900K  
750K / 700K  
540K / 520K

**3-Zone Pad**



### PCY100

Size: 10-inch

► DTX 540K / 520K

**2-Zone & 3-Zone Pad**

### PCY65S

**2-Zone Pad**



### HH65

► DTX 540K / 520K / 500K

### KP65

► DTX 750K / 700K  
540K / 520K / 500K

### PCY65

DTX 500K

**1-Zone Pad**



### RHH135

**2-Zone Pad**

Size: 13-inch





► DTX 950K / 900K  
750K / 700K



### KP125W

Size: 12-inch  
► DTX 950K / 900K

# SPECIFICATIONS

MODEL		DTX950K	DTX900K	DTX750K
Snare		XP120SD for SNARE	3-Zone Pad <small>Head / Open Rim / Quads Rim</small>	XP100SD for SNARE
Tom 1		XP100T for TOM	3-Zone Pad <small>Head / Open Rim / Quads Rim</small>	XP80
Tom 2		XP100T for TOM	3-Zone Pad <small>Head / Open Rim / Quads Rim</small>	XP80
Floor Tom 1		XP120T for TOM	3-Zone Pad <small>Head / Open Rim / Quads Rim</small>	XP80
Floor Tom 2		XP120T for TOM	3-Zone Pad <small>Head / Open Rim / Quads Rim</small>	
Kick Pad		KP125W		
HH Pad		RHH135	2-Zone Pad <small>Down / Edge</small>	
Crash Cymbal 1		PCY135	3-Zone Pad <small>Cap / Rim / Edge</small>	
Crash Cymbal 2		PCY135	3-Zone Pad <small>Cap / Rim / Edge</small>	PCY135
Ride Cymbal		PCY155	3-Zone Pad <small>Cap / Rim / Edge</small>	PCY155
Rack		HXR4LD (HEXRACK)	RS130	RS700
Tone Generator	Polyphony	64		64
	Voices	1,115 drums + 211 melodies		1,268 drums +
	Drum Kit	100 (50 user kits)		120
	Songs	3 Demos, 44 songs, 40 Pad songs		2 Demos, 44 songs,
Expandability		You can add up to 5 pads	You can add up to 6 pads	You can add up to 2 pads
Input / Output		   		
Sampling / Cubase AI	<input type="radio"/> Available <input checked="" type="radio"/> Not Available	<input type="radio"/> / <input type="radio"/>	<input type="radio"/> / <input type="radio"/>	<input checked="" type="radio"/> / <input type="radio"/>

 STANDARD PHONE L/R  Individual OUT x 6  To Host / Device



DTX900



DTX700



DTX500

## DTX900 SPECIFICATIONS

### Tone Generator

Polyphony 64 notes  
 Voices Drum and percussion: 1,115, Melodies: 211  
 Preset: 50, User: 50  
 Drum Kits External: 1584 (or 99 x 16, in the external USB storage device)  
 Effects Reverb: 9, Chorus: 19, Variation: 51 (Drum Kit), Insertion: 51 (AUX IN/SAMPLING IN), Master Effect: 9, Master EQ: 5 bands

### Sequencer

Note Capacity Approx. 152,000 notes  
 Note Resolution 480 ppq (parts per quarter note)  
 Song Recording type Real-time  
 Song tracks 2 tracks  
 Songs Demo: 3, Practice: 44, Pad: 40, User: 50  
 Sequence Format Proprietary, SMF format 0

### Audio Import

Sampling Available \*Requires Optional DIMM installed  
 Samples 1,016  
 Sample Data Bits 16 bits  
 Sampling Time 44.1kHz: 6 min. 20 sec.  
 \* Mono/Stereo 22.05kHz: 12 min. 40 sec.  
 11.025kHz: 25 min. 20 sec.  
 5.5125kHz: 55 min. 40 sec.  
 Sample formats Proprietary, WAV, AIFF

### Click

Tempo 30 to 300 BPM, Tap Tempo supported.  
 Beat 1/4 to 16/4, 1/8 to 16/8, 1/16 to 16/16  
 Timing Accent, Quarter note, Eighth note, Sixteenth note, Triplet  
 Training Functions Measure break, Groove check, Rhythm gate



























### Others

Connectors

- USB TO DEVICE/TO HOST
- OUTPUT [L/MONO] (Standard mono phone)
- OUTPUT [R] (Standard mono phone)
- DIGITAL OUT (EIAJ CP1201, IEC60958, S/P DIF)
- INDIVIDUAL OUTPUT 1 to 6 (Standard mono phone)
- Trigger Input 1 to 9, 12 to 15 (Standard stereo phone, L: Trigger Input, R: Rim Switch)
- Trigger Input 10 and 11 (Standard stereo phone, L: Trigger Input, R: Trigger Input)
- HI-HAT CONTROL (Standard stereo phone)
- AUX IN/SAMPLING IN (Standard stereo phone)
- PHONES (Standard stereo phone)
- MIDI IN/OUT

Dimensions, Weight 334 (W) x 285 (D) x 96 (H) mm, 3.6kg (13-5/32 x 11-15/64 x 3-25/32 inch, 7.94 lbs)  
 Accessories Power Adaptor (PA-300B, or an equivalent), Module holder, Module holder fastening screws x 4, Owner's Manual, Data List, DVD-ROM (Cubase AI)



DTX700K		DTX550K		DTX540K		DTX520K		DTX500K	
XP80 	XP100SD 	XP80 		TP65 					
XP70 	TP65 	XP70 	TP65 						
XP70 	TP65 	XP70 	TP65 						
XP70 	TP65 	XP70 	TP65 						
—									
KP65									
RHH135 	PCY100 		TP65						
PCY135 	PCY100 		PCY65 						
—									
PCY135 	PCY155 	PCY135 		PCY65 					
RS500	RS85A	RS500		RS40					
64	32								
128 melodies	427 drums + 22 melodies								
(60 user kits)	70 (20 user kits)								
17 Pad songs	3 Demos, 41 Practices songs, 19 Pad songs								
You can add up to 3 pads	You can add up to 4 pads								
									
× / ○	× / ×								

## DTX700 SPECIFICATIONS

### Tone Generator

Polyphony	64 notes
Voices	Drum and percussion: 1,268, Melodies: 128
Drum Kits	Preset: 50, User: 10* all of which may be edited and overwritten
Effects	Reverb: 6, Chorus: 6, Variation: 42 Kit EQ: 4 band, Master EQ: 3 bands

### Sequencer

Note Capacity	Approx. 152,000 notes
Note Resolution	480 ppq (parts per quarter note)
Song Recording type	Real-time replace
Song tracks	1 tracks
Songs	Demo: 2, Practice: 44, Pad: 17, User: 30* all of which may be edited and overwritten
Sequence Format	Proprietary, SMF format 0

### Audio Import

Samples	500
Sample Data Bits	16 bits
Sampling Time	44.1kHz: 23 sec. 22.05kHz: 46 sec. 11.025kHz: 1 min. 32 sec. 5.5125kHz: 3 min. 4 sec.
Sample formats	WAV, AIFF

### Click

Tempo	30 to 300 BPM, Tap Tempo supported.
Beat	1/4 to 16/4, 1/8 to 16/8, 1/16 to 16/16
Timing	Accent, Quarter note, Eighth note, Sixteenth note, Triplet

### Training Functions

Others	Measure break, Groove check, Rhythm gate
--------	--

### Connectors

- USB TO DEVICE/TO HOST
- OUTPUT [L/MONO] (Standard mono phone)
- OUTPUT [R] (Standard mono phone)
- Trigger Input 1 to 8, 11 (Standard stereo phone, L: Trigger Input, R: Rim Switch)
- Trigger Input 9 and 10 (Standard stereo phone, L: Trigger Input, R: Trigger Input)
- HI-KICK (Standard stereo phone)
- HI-HAT CONTROL (Standard stereo phone)
- AUX IN (Stereo Mini)

- PHONES (Standard stereo phone)

- MIDI IN/OUT

Dimensions, Weight	277 (W) x 213 (D) x 95 (H) mm, 1.5kg (10-29/32 x 8-25/64 x 2-3/4 inch, 3.31 lbs)
Accessories	Power Adaptor (PA-150, or an equivalent), Module holder, Module holder fastening screws x 4, Owner's Manual, Data List, DVD-ROM (Cubase AI)

## DTX500 SPECIFICATIONS

### Tone Generator

Polyphony	32 notes
Voices	Drum and percussion: 427, Melodies: 22
Drum Kits	Preset: 50, User: 20
Effects	Reverb: 19, Master EQ: 2 bands

### Sequencer

Note Capacity	Approx. 16,000 notes
Note Resolution	96 ppq (parts per quarter note)
Song Recording type	Real-time replace
Song tracks	1 track
Songs	Demo: 3, Practice: 41, Pad: 19, User: 20

### Click

Tempo	30 to 300 BPM, Tap Tempo supported.
Beat	1/4 to 9/4
Timing	Accent, Quarter note, Eighth note, Sixteenth note, Triplet

### Training Functions

Others	Measure break, Groove check, Rhythm gate
--------	--

### Connectors

- OUTPUT [L/MONO] (Standard mono phone)
- OUTPUT [R] (Standard mono phone)
- Trigger Input 1, 5, 6, 7 (Standard stereo phone, L: Trigger Input, R: Rim Switch)
- Trigger Input 2, 3, 4, 8 (Standard stereo phone, L: Trigger Input, R: Trigger Input)
- HI-HAT CONTROL (Standard stereo phone)
- AUX IN (Stereo Mini)
- PHONES (Standard stereo phone)
- MIDI IN/OUT

Dimensions, Weight	252 (W) x 147 (D) x 52 (H) mm, 898g (9-15/16 x 5-13/16 x 2-1/16 inch, 2 lbs)
Accessories	Power Adaptor (PA-130A or PA-3C)

## DTX520K

The centerpiece of a drummer's performance is the snare drum. This model features the DTX-PAD snare pad which greatly enhances your practice sessions by giving you the proper response to improve your technique.



\*Foot pedal not included.  
\*Wiring not shown.

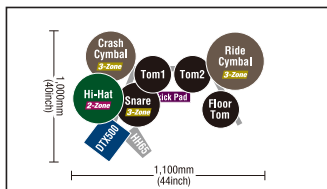

### DTX520K SPECIFICATIONS

Module	DTX500	
Pad Snare	XP80	3-zone Pad
Tom1,2	XP65×2	1-zone Pad
Floor Tom	XP65	1-zone Pad
Crash Cymbal	PCY100	3-zone Pad
Ride Cymbal	PCY135	3-zone Pad
Hi-Hat	RHH100	2-zone Pad
(Hi-Hat stand)	HH65	
Kick	KP65	
Rack	RS500	

## DTX500K

Designed as an entry model to the DTXdrums line of drum products this system features great training functions to help improve your skills at home. The rack system is fold-able for easy storage and the kit includes a genuine Yamaha bass drum pedal.



\*Foot pedal included.  
\*Wiring not shown.

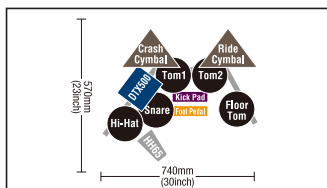

### DTX500K SPECIFICATIONS

Module	DTX500	
Pad Snare	XP65	1-zone Pad
Tom1,2	XP65×2	1-zone Pad
Floor Tom	XP65	1-zone Pad
Crash Cymbal	PCY65	1-zone Pad
Ride Cymbal	PCY65	1-zone Pad
Hi-Hat	TP65	
(Hi-Hat controller)	HH65	
Kick	KP65	
(Foot pedal)	FP6110A	
Rack	RS40	

ELECTRONIC PERCUSSION PAD

# DTX-MULTI 12

The DTX-MULTI 12 is an electronic percussion pad equipped with 12 trigger pads and an onboard library of sounds that include drums, percussion, pitched instruments, ethnic instruments, DJ sounds, and sound effects. You can import 64MB of custom samples, expand the unit with five drum triggers or pads, or connect via USB to a computer. The DTX-MULTI 12 suits any playing style, and provides drummers at all levels with unlimited inspiration from its all-in-one design.

## MULTI VOICES AND EFFECTS

The DTX-MULTI 12 comes loaded with a total of 1,277 voices that include an expansive collection of stunning voices and effects from our renowned MOTIF Series synthesizers plus a wealth of new percussion sounds. You can use this extensive palette of percussive tones to create custom kits that fit your playing needs.

## MULTI PLAY MODES

Stick Mode, Hand Mode, Finger Mode. The DTX-MULTI 12 lets you choose the way you want to play and best express yourself.

## MULTI ASSIGNMENTS

Up to four voices can be assigned to a single pad for simultaneous or sequential playback. You can also have voices that change according to your dynamics. This opens up a wide range of playing possibilities.

## MULTI PATTERNS

A total of 128 phrase patterns covering a wide range of musical styles are included with the DTX-MULTI 12. User memory allocations are also provided so you can record your own patterns and assign them to the pads. A sophisticated click track function even lets you control the tempo live-off-the-floor.

## MULTI PURPOSE

The DTX-MULTI 12 features make it flexible enough for Multiple applications. It's a great solution for anyone looking to:

- 1: Easily add electronics to an acoustic drum kit
- 2: Complement hand drums with a full palette of percussion sounds
- 3: Integrate electronic percussion and drums into their computer based music production system
- 4: Create a compact drum kit for portable playability



 CUBASE AI

USB

## Option

Stand  
**PS940**



Module Attachment  
**MAT1**





## DTX550K

The compact configuration of the DTX550K is centered on the Snare, Hi-Hat and Ride Cymbal, three of the core components of any drum kit. With an amazing feel and a diverse array of functions, the DTX550K comes with an impressive range of sounds that make it an ideal choice, whether practicing at home or performing live on stage.



\*Foot pedal not included.  
\*Wiring not shown.

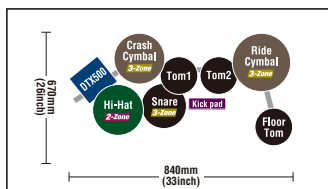

### DTX550K SPECIFICATIONS

Module	DTX500	
Pad Snare	XP100SD	3-zone Pad
Tom1,2	TP65x2	1-zone Pad
Floor Tom	TP65	1-zone Pad
Crash Cymbal	PCY135	3-zone Pad
Ride Cymbal	PCY155	3-zone Pad
Hi-Hat	RHH135	2-zone Pad
(Hi-Hat stand)	HS650A	
Kick	KP65	
Rack	RS85A	

## DTX540K

The advanced cymbals of this kit let you play the bell, bow and edge and are choke-able for more realistic performance. The DTX-PAD snare allows for head, cross-stick and rim shot and all DTX-PAD toms and floor tom make this a superb set for honing real drum technique with dynamic expression.



\*Foot pedal not included.  
\*Wiring not shown.

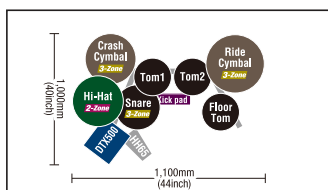

### DTX540K SPECIFICATIONS

Module	DTX500	
Pad Snare	XP80	3-zone Pad
Tom1,2	XP70x2	1-zone Pad
Floor Tom	XP70	1-zone Pad
Crash Cymbal	PCY100	3-zone Pad
Ride Cymbal	PCY135	3-zone Pad
Hi-Hat	RHH100	2-zone Pad
(Hi-Hat stand)	HH65	
Kick	KP65	
Rack	RS500	

# DTX700 series

The sound and feel make you think you're playing acoustic drums. The on-board training functions, the ability to load your own samples via USB, plus the ability to connect directly to a computer make the DTX700 series a serious tool for the modern drummer.

## Features

### No Compromise Sound Quality

There are a total of 1,396 sounds covering a broad spectrum of instruments, including an essential selection of Yamaha acoustic drum sounds like Oak Custom series, as well as percussion and effect sounds. It also contains a wide variety of sounds from Yamaha's famed MOTIF XF synthesizer. Used in combination with the DTX-PAD, the DTX700 module delivers even greater expressiveness and realism.



### Import Original Voices Via The USB Jack

Using a USB memory device, it's easy to import your favorite voices (WAV/AIFF) into the DTX700. Once in the device you can edit and assign the voices to pads to create your own, original drum kit.



### Hi-Hat With Real Playability

This full-fledged hi-hat system consists of a pad that sets onto the supplied hi-hat stand—the same type of stand typically used in an acoustic drum kit. This hi-hat pad system can play both open and closed sounds as well as a foot splash. It also uses a 2-zone design consisting of edge and bow sections, which add to its realistic feel and playability.



### Use for Recording Or Music Production

The DTX700 easily connects to a computer via a USB cable (sold separately) making it a great for recording MIDI data into a DAW or for playing a VST sound source.

Steinberg's Cubase AI is included with the kit so you can start creating music right away.

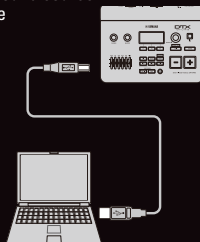



## DTX750K

This kit provides greater freedom in setting and a realistic drumming experience. Not only can you perform using the high-quality internal sounds, you can also connect to a computer for use as the optimal VST instrument controller.



\*Foot pedal not included.  
\*Wiring not shown.

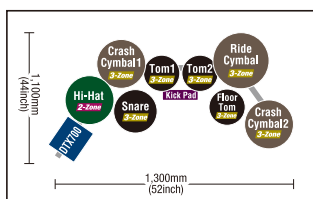

### ■ DTX750K SPECIFICATIONS

Module	DTX700	
Pad Snare (Snare stand)	XP100SD	3-zone Pad
	SS662	
Tom1,2	XP80×2	3-zone Pad
Floor Tom	XP80	3-zone Pad
Crash Cymbal1,2	PCY135×2	3-zone Pad
Ride Cymbal	PCY155	3-zone Pad
Hi-Hat (Hi-Hat stand)	RHH135	2-zone Pad
	HS650A	
Kick	KP65	
Rack	RS700	

## DTX700K

Combining the superior playability of the DTX-PADs, real hi-hat controller and natural sounds, this system is superb for authentic training to really improve your acoustic drumming skills.



\*Foot pedal not included.  
\*Wiring not shown.

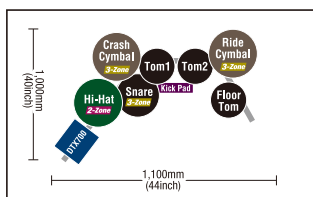

### ■ DTX700K SPECIFICATIONS

Module	DTX700	
Pad Snare	XP80	3-zone Pad
Tom1,2	XP70×2	1-zone Pad
Floor Tom	XP70	1-zone Pad
Crash Cymbal1,2	PCY135	3-zone Pad
Ride Cymbal	PCY135	3-zone Pad
Hi-Hat (Hi-Hat stand)	RHH135	2-zone Pad
	HS650A	
Kick	KP65	
Rack	RS500	

# DTX900 series

The ultimate fusion of natural response and advanced technology lets you express yourself anytime you feel the need to groove.

## Features

### Delivers Real Playability

Experience the ultimate in feel and playability with the 3-zone DTX-PAD used for snare and tom drums, also the hi-hat controlled with the hi-hat stand, 3-zone cymbal pads that produce different sounds according to where the pad is hit, the large kick pad, and more.

### Add Original Sounds With Sampling

You can load data from an external source into the module then assign the voices to the pads to play. You can also sample external sound sources directly into the unit via the AUX IN jack, or even sample yourself playing. Once in the device, data can be processed with the onboard effects, etc., to create your own, original drum kit.



### Outstanding Performance For Performing Live, Recording, Or Music Production

Authentic acoustic drum sounds, expertly engineered drum sounds, percussion sounds, and more; the DTX900 Drum Trigger Module provides a wide-ranging collection that covers nearly any musical style. Superior sound quality meets the demands necessary for stage or recording use. Accompanied with Steinberg's Cubase AI DAW application, all you need to do is connect the module to a computer with a USB cable (sold separately) and start creating music right away.

### Unique DTX Functions Deliver Awe-Inspiring Expressive Power

Powerful capabilities like the Stack Function, which layers multiple voices on a single pad and plays them simultaneously, and the Alternate Function, which changes the voice each time the pad is struck, are unique to DTXdrums. These let you create original ways to play that are impossible to perform with acoustic drums.

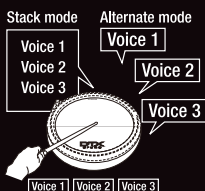

# DTX950K

The embodiment of Yamaha's signature obsession for quality. Providing the full natural expressiveness attainable only with the best kits, this set truly unleashes the drummer's musical potential.



\*Foot pedal not included.  
\*Wiring not shown.

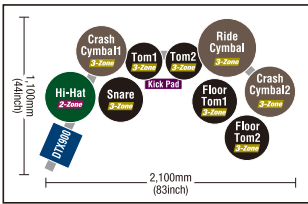

## DTX950K SPECIFICATIONS

Module	DTX900	
Pad Snare (Snare stand)	XP120SD	3-zone Pad SS662
Tom1,2	XP100T×2	3-zone Pad
Floor Tom1,2	XP120T×2	3-zone Pad
Crash Cymbal1,2	PCY135×2	3-zone Pad
Ride Cymbal	PCY155	3-zone Pad
Hi-Hat (Hi-Hat stand)	RHH135	2-zone Pad HS740A
Kick	KP125W	
Rack	HXR4LD (HEXRACK)	

# DTX900K

Superb expression and responsiveness in a professional quality system. Whether you're working on a new lick or simply letting your imagination run wild, this balanced configuration of top-spec components is perfect for every type of drumming.



\*Foot pedal not included.  
\*Wiring not shown.

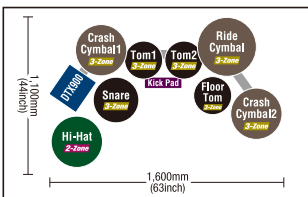

## DTX900K SPECIFICATIONS

Module	DTX900	
Pad Snare (Snare stand)	XP120SD	3-zone Pad SS662
Tom1,2	XP100T×2	3-zone Pad
Floor Tom	XP100T	3-zone Pad
Crash Cymbal1,2	PCY135×2	3-zone Pad
Ride Cymbal	PCY155	3-zone Pad
Hi-Hat (Hi-Hat stand)	RHH135	2-zone Pad HS740A
Kick	KP125W	
Rack	RS130	

## The DTX-PAD Offers The Ideal Feel

After years of designing and manufacturing some of the world's finest drums, Yamaha knows what it means for drums to feel good and play naturally. We designed the DTX-PAD to be the new standard in electronic drum pads, providing drummers with a pad that feels good, offers playability that is as close as possible to acoustic drums, and is exceptionally quiet. Teaming up with the world's top drummers to satisfy their demanding sense of perfection, we focused our knowledge and experience into designing the DTX-PAD. This next generation drum pad allows for true development of acoustic drumming techniques.

Pad Controller



### Pad Controller

Pad pitch and snare tension are adjustable from the pad with a single knob.  
(XP120SD/T, XP100SD/T)



### Rim

A 3-zone design offers the same expressive capabilities as acoustic drums, making closed rim shots, open rim shots, and other playing techniques possible (excluding the XP70).



Open Rim Shot



Closed Rim Shot

Closed Rim Shot

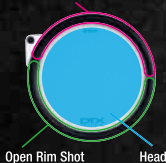

Open Rim Shot

Head

### TCS Head

(Textured Cellular Silicone Head)

Like a coated head on an acoustic drum, a certain amount of roughness helps to control stick slippage after hitting the head. This provides stick control comparable to that on an acoustic drum.



We believe  
**DTXdrums**



Akira Jimbo



Teddy Campbell



## Floating System

Designing the pad with a floating playing surface improves pad sensitivity. This allows it to clearly articulate accents from *ff* to *pp* and detailed ghost notes—all essential requirements for drums.

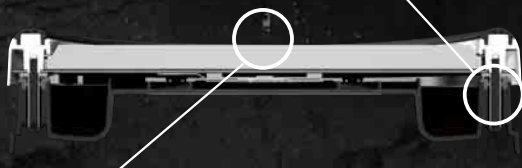

## TCS Head Incorporates A Bubbled Structure

Inside the TCS head are a countless number of tiny bubbles. Controlling the size and density of the bubbles produces a variety of advantages.

### Stick Control Close To Acoustic Drums

Stick control on the pad surface has been fine-tuned to a level that is close to what you experience on an acoustic drum. Rebound is natural with just the right amount of bounce to get the stick back into position in time for the next stroke. Snare and tom pads also have a slightly different response so as you move around the set it feels almost as natural as an acoustic kit. (XP120SD/T, XP100SD/T)

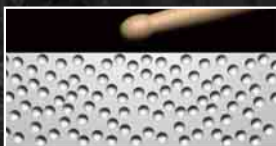

- **Feels Comfortable To Play**

Years of research has resulted in a playing surface that offers optimum rebound and stiffness delivering playing comfort that makes it hard to stop playing.

- **Extremely Quiet**

Bubbles in the TCS head act to cushion the stick's blow reducing the amount of "sound" produced when playing.

- **Reduces Stress On Wrists And Elbows**

When the stick hits the pad's surface, the bubbles absorb the shock to significantly reduce stress on wrists and elbows.



Chris Hesse  
(Hoobastank)



Ndugu Chancler



Russ Miller



Marvin McQuitty



# DTX

drums

## The One to Beat

The DTXdrums series electronic drum sets - Created for all drummers with a passion to be the best that they can be.

The realistic feel and rich expressive sound of these instruments will take you to even greater musical heights.

### What Can Electronic Drums Do?

Yamaha's DTXdrums are on the cutting edge of sound, playability, and expressiveness in pursuit of the ultimate in electronic drums, and expanding the possibilities of the instrument.

### Play With A Broad Range Of Sounds

The possibilities are endless. Choose kits from a collection of essential Yamaha acoustic drum sounds, or select from the broad range of drum, percussion, and effect sounds. Play sounds from kits that professional drummers use or play digital sounds that electronic drums are known for. You can expand on this by processing the sounds with the built-in effects, or create your own original voices, incorporating them into kits that expand your playing potential.

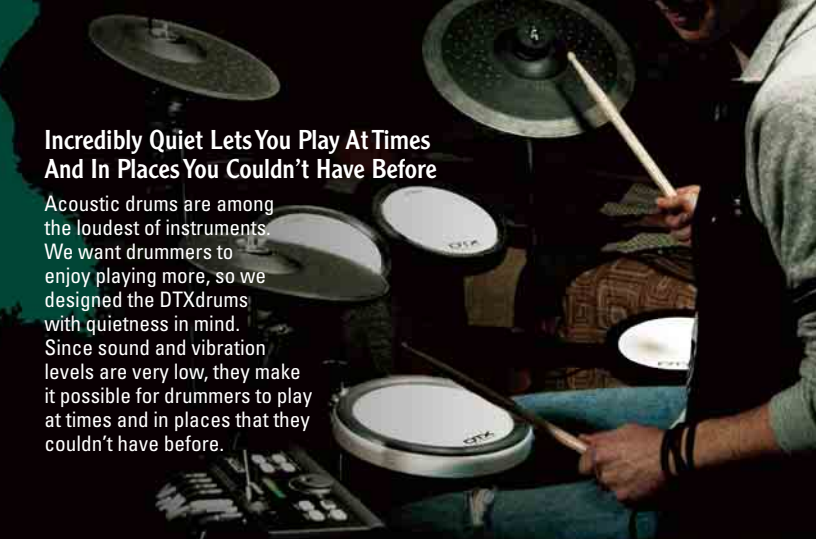

## Incredibly Quiet Lets You Play At Times And In Places You Couldn't Have Before

Acoustic drums are among the loudest of instruments. We want drummers to enjoy playing more, so we designed the DTXdrums with quietness in mind. Since sound and vibration levels are very low, they make it possible for drummers to play at times and in places that they couldn't have before.

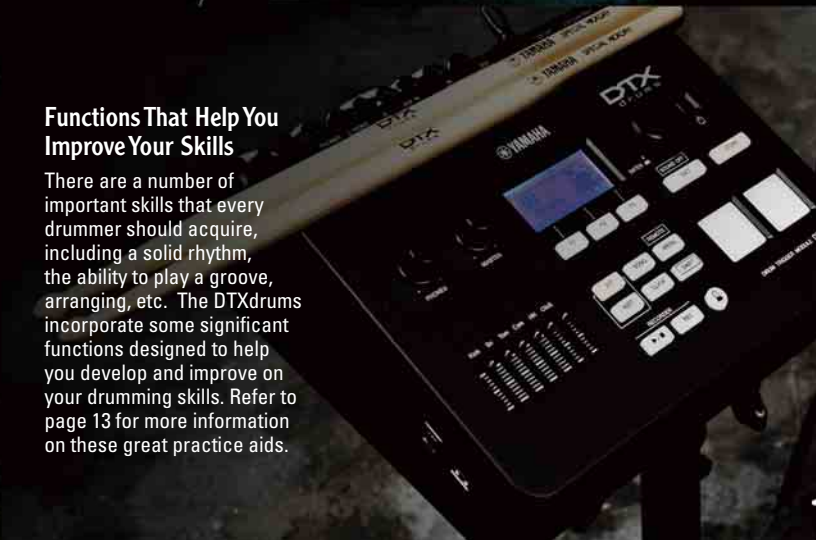

## Functions That Help You Improve Your Skills

There are a number of important skills that every drummer should acquire, including a solid rhythm, the ability to play a groove, arranging, etc. The DTXdrums incorporate some significant functions designed to help you develop and improve on your drumming skills. Refer to page 13 for more information on these great practice aids.



## Performing Live or Recording

With their superior sounds and exceptional feel and playability, the DTXdrums are perfect for practice, performing live, or recording. They can also be connected with a USB cable to a computer and used as an interface for recording MIDI data into a DAW application, or for playing a VST tone generator.



 **YAMAHA**

# DTX

drums

<http://asia.yamaha.com/en/products/musical-instruments/drums/el-drums/>



P 10023651

Printed in Japan